



INTERNATIONAL EQUIPMENT COMPONENTS, INC.
www.levelingmounts.com & www.iec-corp.com

HEAVY-DUTY LEVELERS



ANY THREAD . . . ANY LENGTH . . . ANY BASE



**LEVEL
ALIGN
STABILIZE
PROTECT**

Ph. 562.597.4533

Welcome...

We are pleased to introduce our greatly expanded line of levelers, furniture glides, caps, floor and noise protection products and accessories.

This sectional catalog for **heavy-duty levelers** includes our *slant base* and *low-profile stud* and *socket levelers* and *toggle pads* featuring steel, stainless steel, extended length stud, delrin® base and metric thread options.

We've included a *product overview*, *selection guide* and *quote request* form for both standard and custom products.

IEC's mission since 1992 has been to design, manufacture and supply products that continuously meet the high standards and specifications of OEM equipment and furniture manufacturers. We recognize the need in these industries for improved leveler designs with added features at lower prices. We have made every effort possible to include these product improvements in this catalog.

Paying attention to what our customers have been saying for over 20 years has enabled IEC to become the leader in leveling solution design and development. This has resulted in thousands of new products, stronger customer service and the assurance that the products you specify today will be available for the duration of your product life-cycle.

IEC provides the industry's most complete line of standard and custom leveling devices in "*any thread...any length...any base.*" We appreciate your interest and hope to hear from you whenever you need a leveling solution that will put you on the "*right foot.*"

Sincerely,

A handwritten signature in cursive script that reads "Ron Lassy".

Marketing Manager



CONTENTS

WELCOME

CONTENTS.....3
 PRODUCT OVERVIEW4
 SELECTION GUIDE5

SLANT BASE LEVELERS

Slant Base Socket Levelers - Steel & Stainless Steel6
 Slant Base Socket Levelers - Steel & Stainless Steel with Rubber Pad6
 Slant Base Socket Levelers - Delrin Base, Steel & Stainless Steel7
 Slant Base Socket Levelers - Metric Steel & Stainless Steel8
 Slant Base Socket Levelers - Metric Steel & Stainless Steel with Rubber Pad8
 Slant Base Socket Levelers - Metric Delrin Base, Steel & Stainless Steel8
 Slant Base Stud Levelers - Steel & Stainless Steel9
 Slant Base Stud Levelers - Steel & Stainless Steel with Rubber Pad9
 Slant Base Stud Levelers - Extended Stud Lengths Steel & Stainless Steel10
 Slant Base Stud Levelers - Extended Stud Lengths Steel & Stainless Steel with Rubber Pad10
 Slant Base Stud Levelers - Delrin Base, Steel & Stainless Steel11
 Slant Base Stud Levelers - Extended Stud Lengths Delrin Base, Steel & Stainless Steel11
 Slant Base Stud Levelers - Metric Steel & Stainless Steel12
 Slant Base Stud Levelers - Metric Steel & Stainless Steel with Rubber Pad12
 Slant Base Stud Levelers - Metric Delrin Base, Steel & Stainless Steel12
 Slant Base Stud Levelers - Metric Extended Stud Lengths Steel & Stainless Steel13
 Slant Base Stud Levelers - Metric Extended Stud Lengths Steel & Stainless Steel with Rubber Pad13
 Slant Base Stud Levelers - Metric Extended Stud Lengths Delrin Base, Steel & Stainless Steel13

LOW PROFILE LEVELERS

Low-Profile Socket Levelers - Steel & Stainless Steel14
 Low-Profile Metric Socket Levelers - Steel & Stainless Steel15
 Low-Profile Stud Levelers - Steel & Stainless Steel - 2" Stud Lengths16
 Low-Profile Stud Levelers - Steel & Stainless Steel - 3" Stud Lengths17
 Low-Profile Stud Levelers - Steel & Stainless Steel - 4" Stud Lengths18
 Low-Profile Stud Levelers - Steel & Stainless Steel - 5" Stud Lengths19
 Low-Profile Stud Levelers - Steel & Stainless Steel - 6" Stud Lengths20
 Low-Profile Stud Levelers - Steel & Stainless Steel - 8" Stud Lengths21
 Low-Profile Metric Stud Levelers - Steel & Stainless Steel - 2",3",4",5",6" & 8" Stud Lengths22-27

TOGGLE PADS

Toggle Pads Socket - Steel & Stainless Steel28
 Toggle Pads Socket - Delrin Base Steel & Stainless Steel28
 Toggle Pads Socket - Metric Steel & Stainless Steel29
 Toggle Pads Socket - Metric Delrin Base Steel & Stainless Steel29
 Toggle Pads Stud - Steel & Stainless Steel30
 Toggle Pads Stud - Delrin Base Steel & Stainless Steel32
 Toggle Pads Stud - Metric Steel & Stainless Steel34
 Toggle Pads Stud - Metric Delrin Base Steel & Stainless Steel36

THREADED TUBE ENDS

Threaded Tube Ends38

RFQ FAX-BACK FORM

Request A Quote Form40
 Warranty and Disclaimer41



HEAVY DUTY LEVELERS

SLANT BASE — SOCKET LEVELERS (Inch and Metric)

The IEC *Slant Base Socket Leveler* is ideal for heavy-duty loads where a stud is not required. Integrated ball and swivel socket provide a low-friction support interface. Ideal for cabinets, instruments, machinery and equipment. Steel, stainless steel and delrin® base models.



SLANT BASE — STUD LEVELERS (Inch and Metric)

The IEC *Slant Base Stud Leveler* is ideal for heavy-duty loads. Integrated ball and swivel socket provide a low-friction support interface. Ideal for cabinets, instruments, machinery and equipment. Steel, stainless steel and delrin® base models.



LOW PROFILE — SOCKET LEVELERS (Inch and Metric)

The IEC *Low-Profile Socket Leveler* features an exclusive ball design that minimizes base separation. Ideal for heavy-duty load requirements. Threaded female socket allows use of your own stud or bolt. Integrated ball and swivel socket offer a low-friction support interface. Perfect for cabinets, instruments, machinery and equipment.



LOW PROFILE — STUD LEVELERS (Inch and Metric)

The IEC *Low-Profile Stud Leveler* features an exclusive ball design that minimizes base separation. Ideal for heavy-duty load requirements. Integrated ball and swivel socket offer a low-friction support interface. Perfect for cabinets, instruments, machinery and equipment.



TOGGLE PADS — SOCKET (Inch and Metric)

IEC *Stud Toggle Pads* feature an exclusive ball design that minimizes base separation. Ideal for heavy-duty loads. The threaded female socket allows use of your own stud or bolt. Integrated ball and swivel socket provide a low-friction support interface. Steel, stainless steel and delrin® base models.



TOGGLE PADS — STUD (Inch and Metric)

IEC *Stud Toggle Pads* feature an exclusive ball design that minimizes base separation. Ideal for heavy-duty loads. The threaded female socket allows use of your own stud or bolt. Integrated ball and swivel socket provide a low-friction support interface. Steel, stainless steel and delrin® base models.





Features by Leveler Family	Slant Base Socket	Slant Base Stud	Low Profile Socket	Low Profile Stud	Toggle Pad Socket	Toggle Pad Stud
Steel	Yes	Yes	Yes	Yes	Yes	Yes
Stainless Steel	Yes	Yes	Yes	Yes	Yes	Yes
Load Range	to 20,000 lbs.	to 20,000 lbs.	to 10,000 lbs.	to 10,000 lbs.	to 5,000 lbs.	to 5,000 lbs.
Inch Threads	1/4-20 to 1-12	1/4-20 to 1-12	1/4-20 to 1-8	1/4-20 to 1 1/4-7	1/4-20 to 1-8	1/4-20 to 1-8
Metric Threads	M6-M24	M6-M24	M6-M24	M6-M24	M6-M24	M6-M24
Stud Lengths	N / A	2" to 8"	N / A	2" to 8"	N / A	2" to 8"
Top Thread Adjustment	N / A	Yes	N / A	Yes	N / A	Yes
Swivel Base	Yes	Yes	Yes	Yes	Yes	Yes
Optional Lag Holes	N / A	N / A	Yes	Yes	N / A	N / A
Base Diameters	1" to 4"	1" to 4"	3/4" to 4"	3/4" to 4"	3/4" to 1 1/4"	3/4" to 1 1/4"
Optional Delrin Base	Yes	Yes	N / A	N / A	Yes	Yes
Optional Rubber Pad	Yes	Yes	Yes	Yes	Yes	Yes
Standard Finish Gold Iridite - Zinc	Yes	Yes	Yes	Yes	Yes	Yes
Optional Finish Black Oxide	Yes	Yes	Yes	Yes	Yes	Yes
Catalog Page	6-8	19-13	14-15	16-27	28-29	30-36



SLANT BASE SOCKET LEVELERS

The IEC *Slant Base Socket Leveler* is ideal for heavy-duty loads where a stud is not required. Integrated ball and swivel socket provide a low-friction support interface. Ideal for cabinets, instruments, machinery and equipment.

Features

- Solid steel/stainless steel
- Integrated ball and socket
- Adjustable height
- Base adjusts 15° off centerline
- Standard gold irridite zinc finish
- Black chromate or clear chromate options
- Rubber pad or non-marring delrin base

Applications

- Equipment benches
- Machinery
- Instruments
- Enclosures

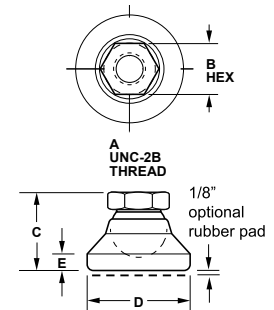

STEEL & STAINLESS STEEL

Steel	SS	Load	A	B	C	D	E
IL1-4G	IL5-4	1400	1/4-20	1/2	45/64	1	5/32
IL1-4GF	IL5-4F	1400	1/4-28	1/2	45/64	1	5/32
IL1-6G	IL5-6	3000	3/8-16	5/8	7/8	1-1/4	3/16
IL1-6GF	IL5-6F	3000	3/8-24	5/8	7/8	1-1/4	3/16
IL1-7G	IL5-7	5500	1/2-13	3/4	1-1/8	1-7/8	1/4
IL1-7GF	IL5-7F	5500	1/2-20	3/4	1-1/8	1-7/8	1/4
IL1-8G	IL5-8	6000	5/8-11	7/8	1-1/4	2-1/2	5/16
IL1-8GF	IL5-8F	6000	5/8-18	7/8	1-1/4	2-1/2	5/16
IL1-9G	IL5-9	8000	3/4-10	1-1/16	1-1/2	3	1/2
IL1-9GF	IL5-9F	8000	3/4-16	1-1/16	1-1/2	3	1/2
IL1-10G	IL5-10	20000	1-8	1-1/2	1-7/8	4	13/32
IL1-10GF	IL5-10F	20000	1-12	1-1/2	1-7/8	4	13/32

STEEL & STAINLESS STEEL WITH RUBBER PAD

Steel	SS	Load	A	B	C	D	E
IL1-4G-P	IL5-4-P	1050	1/4-20	1/2	53/64	1	5/32
IL1-4GF-P	IL5-4F-P	1050	1/4-28	1/2	53/64	1	5/32
IL1-6G-P	IL5-6-P	2250	3/8-16	5/8	1	1-1/4	3/16
IL1-6GF-P	IL5-6F-P	2250	3/8-24	5/8	1	1-1/4	3/16
IL1-7G-P	IL5-7-P	3750	1/2-13	3/4	1-1/4	1-7/8	1/4
IL1-7GF-P	IL5-7F-P	3750	1/2-20	3/4	1-1/4	1-7/8	1/4
IL1-8G-P	IL5-8-P	4500	5/8-11	7/8	1-3/8	2-1/2	5/16
IL1-8GF-P	IL5-8F-P	4500	5/8-18	7/8	1-3/8	2-1/2	5/16
IL1-9G-P	IL5-9-P	6000	3/4-10	1-1/16	1-5/8	3	1/2
IL1-9GF-P	IL5-9F-P	6000	3/4-16	1-1/16	1-5/8	3	1/2
IL1-10G-P	IL5-10-P	15000	1-8	1-1/2	2	4	13/32
IL1-10GF-P	IL5-10F-P	15000	1-12	1-1/2	2	4	13/32



INTERNATIONAL EQUIPMENT COMPONENTS, INC.
 Phone: 562.597.4533 eMail: sales@iec-corp.com
 Web: www.levelingmounts.com & www.iec-corp.com

HEAVY-DUTY LEVELERS

SLANT BASE SOCKET - DELRIN

SLANT BASE SOCKET LEVELERS

The IEC *Slant Delrin® Base Socket Leveler* is ideal for heavy-duty loads where a stud is not required. Integrated ball and swivel socket provide a low-friction support interface. Ideal for cabinets, instruments, machinery and equipment.

Features

- Solid steel/stainless steel
- Integrated ball and socket
- Adjustable height
- Base adjusts 15° off centerline
- Standard gold irridite zinc finish
- Black chromate or clear chromate options
- Non-marring delrin base

Applications

- Equipment benches
- Machinery
- Instruments
- Enclosures

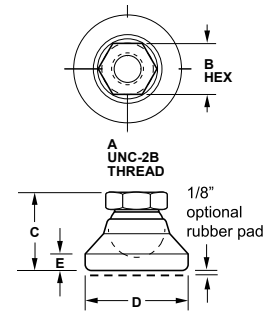

DELRIN BASE - STEEL & STAINLESS STEEL

Steel	SS	Load	A	B	C	D	E
IL3-4W	IL3-4S	200	1/4-20	1/2	45/64	1	5/32
IL3-6W	IL3-6S	300	3/8-16	5/8	7/8	1-1/4	3/16
IL3-7W	IL3-7S	700	1/2-13	3/4	1-1/8	1-7/8	1/4
IL3-8W	IL3-8S	1200	5/8-11	7/8	1-1/4	2-1/2	5/16
IL3-9W	IL3-9S	1800	3/4-10	1-1/16	1-1/2	3	1/2
IL3-10W	IL3-10S	2400	1-8	1-1/2	1-7/8	4	13/32

The delrin® base is white.



SLANT BASE METRIC SOCKET LEVELERS

The IEC *Slant Base Metric Socket Leveler* is ideal for heavy-duty loads where a stud is not required. Integrated ball and swivel socket provide a low-friction support interface. Ideal for cabinets, instruments, machinery and equipment.

Features

- Solid steel/stainless steel
- Integrated ball and socket
- Adjustable height
- Base adjusts 15° off centerline
- Standard gold irridite zinc finish
- Black chromate or clear chromate options
- Rubber pad or non-marring delrin base

Applications

- Equipment benches
- Machinery
- Instruments
- Enclosures

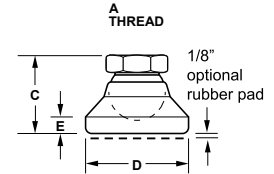
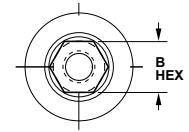

METRIC STEEL & STAINLESS STEEL

Steel	SS	Load	A	B	C	D	E
IL1-M6G	IL5-M6	1400	M6x1	1/2	45/64	1	5/32
IL1-M10G	IL5-M10	3000	M10x1.50	5/8	7/8	1-1/4	3/16
IL1-M12G	IL5-M12	5500	M12x1.75	3/4	1-1/8	1-7/8	1/4
IL1-M16G	IL5-M16	6000	M16x2.00	7/8	1-1/4	2-1/2	5/16
IL1-M20G	IL5-M20	8000	M20x2.50	1-1/16	1-1/2	3	1/2
IL1-M24G	IL5-M24	20000	M24x3.00	1-1/2	1-7/8	4	13/32

METRIC STEEL & STAINLESS STEEL WITH RUBBER PAD

Steel	SS	Load	A	B	C	D	E
IL1-M6G-P	IL5-M6-P	1050	M6x1	1/2	53/64	1	5/32
IL1-M10G-P	IL5-M10-P	2250	M10x1.50	5/8	1	1-1/4	3/16
IL1-M12G-P	IL5-M12-P	3750	M12x1.75	3/4	1-1/4	1-7/8	1/4
IL1-M16G-P	IL5-M16-P	4500	M16x2.00	7/8	1-3/8	2-1/2	5/16
IL1-M20G-P	IL5-M20-P	6000	M20x2.50	1-1/16	1-5/8	3	1/2
IL1-M24G-P	IL5-M24-P	15000	M24x3.00	1-1/2	2	4	13/32

DELRIN BASE - METRIC STEEL & STAINLESS STEEL

Steel	SS	Load	A	B	C	D	E
IL3-M6W	IL3-M6S	200	M6x1	1/2	45/64	1	5/32
IL3-M10W	IL3-M10S	300	M10x1.50	5/8	7/8	1-1/4	3/16
IL3-M12W	IL3-M12S	700	M12x1.75	3/4	1-1/8	1-7/8	1/4
IL3-M16W	IL3-M16S	1200	M16x2.00	7/8	1-1/4	2-1/2	5/16
IL3-M20W	IL3-M20S	1800	M20x2.50	1-1/16	1-1/2	3	1/2
IL3-M24W	IL3-M24S	2400	M24x3.00	1-1/2	1-7/8	4	13/32

The delrin® base is white.



SLANT BASE STUD LEVELERS

The IEC *Slant Base Stud Leveler* is ideal for heavy-duty loads. Integrated ball and swivel socket provide a low-friction support interface. Ideal for cabinets, instruments, machinery and equipment.

Features

- Solid steel/stainless steel
- Integrated ball and socket
- Adjustable height
- Base adjusts 15° off centerline
- Standard gold irridite zinc finish
- Black chromate or clear chromate options
- Rubber pad or non-marring delrin base

Applications

- Equipment benches
- Machinery
- Instruments
- Enclosures

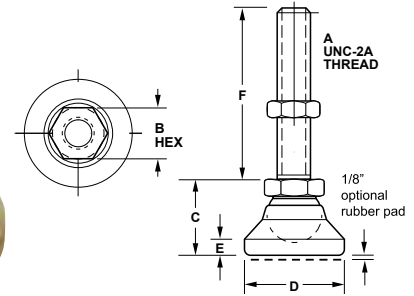

STEEL & STAINLESS STEEL

Steel	SS	Load	A	B	C	D	E	F
IL2-4G	IL6-4	1400	1/4-20	1/2	45/64	1	5/32	1-1/4
IL2-4GF	IL6-4F	1400	1/4-28	1/2	45/64	1	5/32	1-1/4
IL2-6G	IL6-6	3000	3/8-16	5/8	7/8	1-1/4	3/16	2
IL2-6GF	IL6-6F	3000	3/8-24	5/8	7/8	1-1/4	3/16	2
IL2-7G	IL6-7	5500	1/2-13	3/4	1-1/8	1-7/8	1/4	2
IL2-7GF	IL6-7F	5500	1/2-20	3/4	1-1/8	1-7/8	1/4	2
IL2-8G	IL6-8	6000	5/8-11	7/8	1-1/4	2-1/2	5/16	2
IL2-8GF	IL6-8F	6000	5/8-18	7/8	1-1/4	2-1/2	5/16	2
IL2-9G	IL6-9	8000	3/4-10	1-1/16	1-1/2	3	1/2	2
IL2-9GF	IL6-9F	8000	3/4-16	1-1/16	1-1/2	3	1/2	2
IL2-10G	IL6-10	20000	1-8	1-1/2	1-7/8	4	13/32	4-1/4
IL2-10GF	IL6-10F	20000	1-12	1-1/2	1-7/8	4	13/32	4-1/4

Part numbers with an "F" indicate fine threads.

STEEL & STAINLESS STEEL WITH RUBBER PAD

Steel	SS	Load	A	B	C	D	E	F
IL2-4G-P	IL6-4-P	1050	1/4-20	1/2	53/64	1	5/32	1-1/4
IL2-4GF-P	IL6-4F-P	1050	1/4-28	1/2	53/64	1	5/32	1-1/4
IL2-6G-P	IL6-6-P	2250	3/8-16	5/8	1	1-1/4	3/16	2
IL2-6GF-P	IL6-6F-P	2250	3/8-24	5/8	1	1-1/4	3/16	2
IL2-7G-P	IL6-7-P	3750	1/2-13	3/4	1-1/4	1-7/8	1/4	2
IL2-7GF-P	IL6-7F-P	3750	1/2-20	3/4	1-1/4	1-7/8	1/4	2
IL2-8G-P	IL6-8-P	4500	5/8-11	7/8	1-3/8	2-1/2	5/16	2
IL2-8GF-P	IL6-8F-P	4500	5/8-18	7/8	1-3/8	2-1/2	5/16	2
IL2-9G-P	IL6-9-P	6000	3/4-10	1-1/16	1-5/8	3	1/2	2
IL2-9GF-P	IL6-9F-P	6000	3/4-16	1-1/16	1-5/8	3	1/2	2
IL2-10G-P	IL6-10-P	15000	1-8	1-1/2	2	4	13/32	4-1/4
IL2-10GF-P	IL6-10F-P	15000	1-12	1-1/2	2	4	13/32	4-1/4

Part numbers with an "F" indicate fine threads.



SLANT BASE EXTENDED STUD LEVELERS

The IEC *Slant Base Extended Stud Leveler* is ideal for heavy-duty loads. Integrated ball and swivel socket provide a low-friction support interface. Ideal for cabinets, instruments, machinery and equipment.

Features

- Solid steel/stainless steel
- Integrated ball and socket
- Adjustable height
- Base adjusts 15° off centerline
- Standard gold irridite zinc finish
- Black chromate or clear chromate options
- Rubber pad or non-marring delrin base

Applications

- Equipment benches
- Machinery
- Instruments
- Enclosures

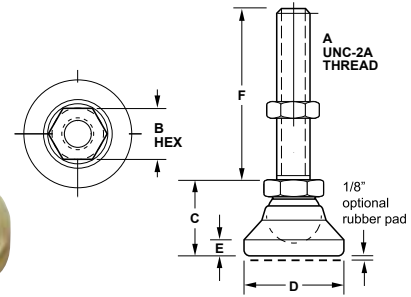

EXTENDED STUD LENGTHS - STEEL & STAINLESS STEEL

Steel	SS	Load	A	B	C	D	E	F
IL2-4Gx2	IL6-4x2	1400	1/4-20	1/2	45/64	1	5/32	2-1/2
IL2-4GFx2	IL6-4Fx2	1400	1/4-28	1/2	45/64	1	5/32	2-1/2
IL2-6Gx4	IL6-6x4	3000	3/8-16	5/8	7/8	1-1/4	3/16	4
IL2-6GFx4	IL6-6Fx4	3000	3/8-24	5/8	7/8	1-1/4	3/16	4
IL2-7Gx4	IL6-7x4	5500	1/2-13	3/4	1-1/8	1-7/8	1/4	4
IL2-7GFx4	IL6-7Fx4	5500	1/2-20	3/4	1-1/8	1-7/8	1/4	4
IL2-8Gx4	IL6-8x4	6000	5/8-11	7/8	1-1/4	2-1/2	5/16	4
IL2-8GFx4	IL6-8Fx4	6000	5/8-18	7/8	1-1/4	2-1/2	5/16	4
IL2-9Gx4	IL6-9x4	8000	3/4-10	1-1/16	1-1/2	3	1/2	4
IL2-9GFx4	IL6-9Fx4	8000	3/4-16	1-1/16	1-1/2	3	1/2	4
IL2-10Gx8	IL6-10x8	20000	1-8	1-1/2	1-7/8	4	13/32	8

Part numbers with an "F" indicate fine threads.

EXTENDED STUD LENGTHS - STEEL & STAINLESS STEEL WITH RUBBER PAD

Steel	SS	Load	A	B	C	D	E	F
IL2-4Gx2-P	IL6-4x2-P	1050	1/4-20	1/2	53/64	1	5/32	2-1/2
IL2-4GFx2-P	IL6-4Fx2-P	1050	1/4-28	1/2	53/64	1	5/32	2-1/2
IL2-6Gx4-P	IL6-6x4-P	2250	3/8-16	5/8	1	1-1/4	3/16	4
IL2-6GFx4-P	IL6-6Fx4-P	2250	3/8-24	5/8	1	1-1/4	3/16	4
IL2-7Gx4-P	IL6-7x4-P	3750	1/2-13	3/4	1-1/4	1-7/8	1/4	4
IL2-7GFx4-P	IL6-7Fx4-P	3750	1/2-20	3/4	1-1/4	1-7/8	1/4	4
IL2-8Gx4-P	IL6-8x4-P	4500	5/8-11	7/8	1-3/8	2-1/2	5/16	4
IL2-8GFx4-P	IL6-8Fx4-P	4500	5/8-18	7/8	1-3/8	2-1/2	5/16	4
IL2-9Gx4-P	IL6-9x4-P	6000	3/4-10	1-1/16	1-5/8	3	1/2	4
IL2-9GFx4-P	IL6-9Fx4-P	6000	3/4-16	1-1/16	1-5/8	3	1/2	4
IL2-10Gx8-P	IL6-10x8-P	15000	1-8	1-1/2	2	4	13/32	8

Part numbers with an "F" indicate fine threads.



SLANT BASE STUD LEVELERS

The IEC *Slant Delrin® Base Stud Leveler* is ideal for heavy-duty loads. Integrated ball and swivel socket provide a low-friction support interface. Ideal for cabinets, instruments, machinery and equipment.

Features

- Solid steel/stainless steel
- Integrated ball and socket
- Adjustable height
- Base adjusts 15° off centerline
- Standard gold irridite zinc finish
- Black chromate or clear chromate options
- Non-marring delrin base

Application:

- Equipment benches
- Machinery
- Instruments
- Enclosures

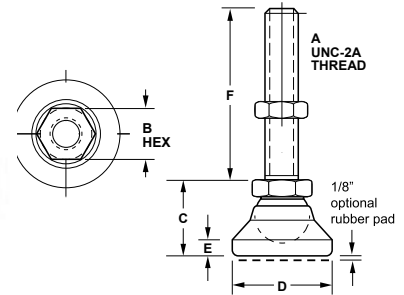

STANDARD STUD LENGTHS - DELRIN BASE

Steel	SS	Load	A	B	C	D	E	F
IL4-4W	IL4-4S	200	1/4-20	1/2	45/64	1	5/32	1-1/4
IL4-6W	IL4-6S	300	3/8-16	5/8	7/8	1-1/4	3/16	2
IL4-7W	IL4-7S	700	1/2-13	3/4	1-1/8	1-7/8	1/4	2
IL4-8W	IL4-8S	1200	5/8-11	7/8	1-1/4	2-1/2	5/16	2
IL4-9W	IL4-9S	1800	3/4-10	1-1/16	1-1/2	3	1/2	2
IL4-10W	IL4-10S	2400	1-8	1-1/2	1-7/8	4	13/32	4-1/4

The delrin® base is white.

EXTENDED STUD LENGTHS - DELRIN BASE

Steel	SS	Load	A	B	C	D	E	F
IL4-4Wx2	IL4-4Sx2	200	1/4-20	1/2	45/64	1	5/32	2-1/2
IL4-6Wx4	IL4-6Sx4	300	3/8-16	5/8	7/8	1-1/4	3/16	4
IL4-7Wx4	IL4-7Sx4	700	1/2-13	3/4	1-1/8	1-7/8	1/4	4
IL4-8Wx4	IL4-8Sx4	1200	5/8-11	7/8	1-1/4	2-1/2	5/16	4
IL4-9Wx4	IL4-9Sx4	1800	3/4-10	1-1/16	1-1/2	3	1/2	4
IL4-10Wx8	IL4-10Sx8	2400	1-8	1-1/2	1-7/8	4	13/32	8

The delrin® base is white.



SLANT BASE METRIC STUD LEVELERS

The IEC *Metric Slant Base Stud Leveler* is ideal for heavy-duty loads. Integrated ball and swivel socket provide a low-friction support interface. Ideal for cabinets, instruments, machinery and equipment.

Features

- Solid steel/stainless steel
- Integrated ball and socket
- Adjustable height
- Base adjusts 15° off centerline
- Standard gold irridite zinc finish
- Black chromate or clear chromate options
- Rubber pad or non-marring delrin base

Applications

- Equipment benches
- Machinery
- Instruments
- Enclosures

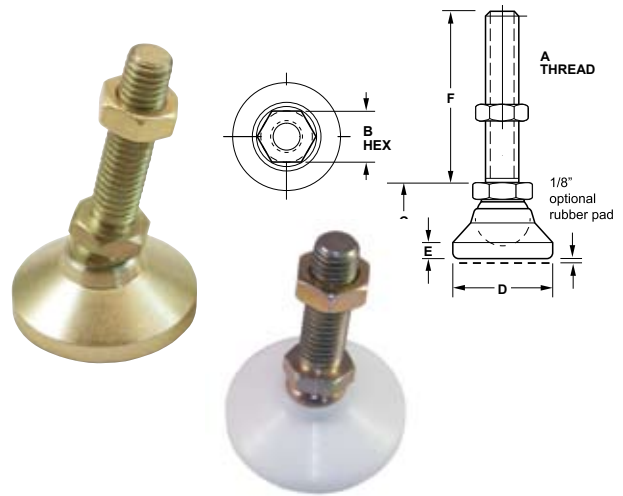

METRIC - STEEL & STAINLESS STEEL

Steel	SS	Load	A	B	C	D	E	F
IL2-M6G	IL6-M6	1400	M6x1	1/2	45/64	1	5/32	1-1/4
IL2-M10G	IL6-M10	3000	M10x1.50	5/8	7/8	1-1/4	3/16	2
IL2-M12G	IL6-M12	5500	M12x1.75	3/4	1-1/8	1-7/8	1/4	2
IL2-M16G	IL6-M16	6000	M16x2.00	7/8	1-1/4	2-1/2	5/16	2
IL2-M20G	IL6-M20	8000	M20x2.50	1-1/16	1-1/2	3	1/2	2
IL2-M24G	IL6-M24	20000	M24x3.00	1-1/2	1-7/8	4	13/32	4-1/4

METRIC - STEEL & STAINLESS STEEL WITH RUBBER PAD

Steel	SS	Load	A	B	C	D	E	F
IL2-M6G-P	IL6-M6-P	1050	M6x1	1/2	53/64	1	5/32	1-1/4
IL2-M10G-P	IL6-M10-P	2250	M10x1.50	5/8	1	1-1/4	3/16	2
IL2-M12G-P	IL6-M12-P	3750	M12x1.75	3/4	1-1/4	1-7/8	1/4	2
IL2-M16G-P	IL6-M16-P	4500	M16x2.00	7/8	1-3/8	2-1/2	5/16	2
IL2-M20G-P	IL6-M20-P	6000	M20x2.50	1-1/16	1-5/8	3	1/2	2
IL2-M24G-P	IL6-M24-P	15000	M24x3.00	1-1/2	2	4	13/32	4-1/4

METRIC DELRIN BASE - STEEL & STAINLESS STEEL

Steel	SS	Load	A	B	C	D	E	F
IL4-M6W	IL4-M6S	200	M6x1	1/2	45/64	1	5/32	1-1/4
IL4-M10W	IL4-M10S	300	M10x1.50	5/8	7/8	1-1/4	3/16	2
IL4-M12W	IL4-M12S	700	M12x1.75	3/4	1-1/8	1-7/8	1/4	2
IL4-M16W	IL4-M16S	1200	M16x2.00	7/8	1-1/4	2-1/2	5/16	2
IL4-M20W	IL4-M20S	1800	M20x2.50	1-1/16	1-1/2	3	1/2	2
IL4-M24W	IL4-M24S	2400	M24x3.00	1-1/2	1-7/8	4	13/32	4-1/4

The delrin® base is white.



HEAVY-DUTY LEVELERS
EXTENDED STUD - METRIC

SLANT BASE METRIC EXTENDED STUD LEVELERS

The IEC *Metric Slant Base Extended Stud Leveler* is ideal for heavy-duty loads. Integrated ball and swivel socket provide a low-friction support interface. Ideal for cabinets, instruments, machinery and equipment.

Features

- Solid steel/stainless steel
- Integrated ball and socket
- Adjustable height
- Base adjusts 15° off centerline
- Standard gold irridite zinc finish
- Black chromate or clear chromate options
- Rubber pad or non-marring delrin base

Applications

- Equipment benches
- Machinery
- Instruments
- Enclosures

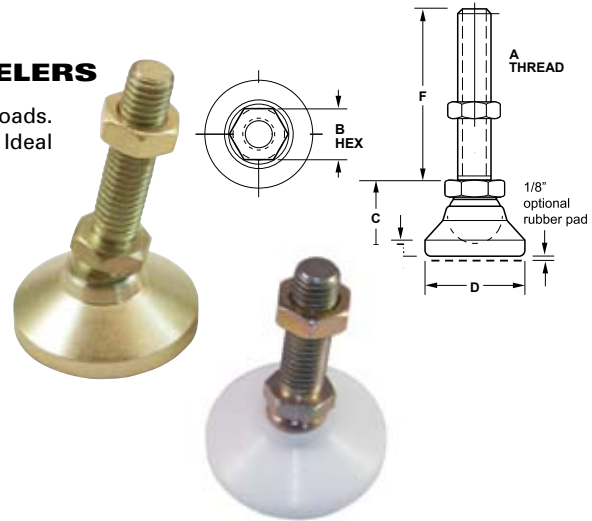

EXTENDED STUD LENGTHS - METRIC STEEL & STAINLESS STEEL

Steel	SS	Load	A	B	C	D	E	F
IL2-M6Gx2	IL6-M6x2	1400	M6x1	1/2	45/64	1	5/32	2-1/2
IL2-M10Gx4	IL6-M10x4	3000	M10x1.50	5/8	7/8	1-1/4	3/16	4
IL2-M12Gx4	IL6-M12x4	5500	M12x1.75	3/4	1-1/8	1-7/8	1/4	4
IL2-M16Gx4	IL6-M16x4	6000	M16x2.00	7/8	1-1/4	2-1/2	5/16	4
IL2-M20Gx4	IL6-M20x4	8000	M20x2.50	1-1/16	1-1/2	3	1/2	4
IL2-M24Gx8	IL6-M24x8	20000	M24x3.00	1-1/2	1-7/8	4	13/32	8

EXTENDED STUD LENGTHS - METRIC STEEL & STAINLESS STEEL WITH RUBBER PAD

Steel	SS	Load	A	B	C	D	E	F
IL2-M6Gx2-P	IL6-M6x2-P	1050	M6x1	1/2	53/64	1	5/32	2-1/2
IL2-M10Gx4-P	IL6-M10x4-P	2250	M10x1.50	5/8	1	1-1/4	3/16	4
IL2-M12Gx4-P	IL6-M12x4-P	3750	M12x1.75	3/4	1-1/4	1-7/8	1/4	4
IL2-M16Gx4-P	IL6-M16x4-P	4500	M16x2.00	7/8	1-3/8	2-1/2	5/16	4
IL2-M20Gx4-P	IL6-M20x4-P	6000	M20x2.50	1-1/16	1-5/8	3	1/2	4
IL2-M24Gx8-P	IL6-M24x8-P	15000	M24x3.00	1-1/2	2	4	13/32	8

DELTRIN BASE - EXTENDED STUD LENGTHS - METRIC STEEL & STAINLESS STEEL

Steel	SS	Load	A	B	C	D	E	F
IL4-M6Wx2	IL4-M6Sx2	200	M6x1	1/2	45/64	1	5/32	2-1/2
IL4-M10Wx4	IL4-M10Sx4	300	M10x1.50	5/8	7/8	1-1/4	3/16	4
IL4-M12Wx4	IL4-M12Sx4	700	M12x1.75	3/4	1-1/8	1-7/8	1/4	4
IL4-M16Wx4	IL4-M16Sx4	1200	M16x2.00	7/8	1-1/4	2-1/2	5/16	4
IL4-M20Wx4	IL4-M20Sx4	1800	M20x2.50	1-1/16	1-1/2	3	1/2	4
IL4-M24Wx8	IL4-M24Sx8	2400	M24x3.00	1-1/2	1-7/8	4	13/32	8

The delrin® base is white.



LOW PROFILE SOCKET LEVELERS

The IEC *Low-Profile Socket Leveler* features an exclusive ball design that minimizes base separation. Ideal for heavy-duty load requirements. The threaded female socket allows use of your own stud or bolt. Integrated ball and swivel socket provide a low-friction support interface. Perfect for cabinets, instruments, machinery and equipment.

Features

- Steel/stainless steel options
- Integrated ball and socket
- Adjustable height
- Base adjusts 15° off centerline
- Standard gold irridite zinc finish
- Black oxide or clear chromate options
- Optional rubber pad (add -P)

Applications

- Electronic equipment
- Enclosures
- Conveyors
- Machinery
- Work tables
- Display racks

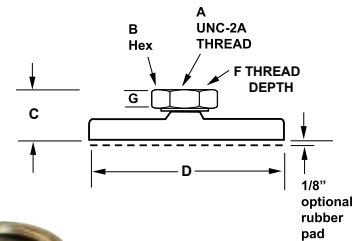

Nut Height: "G" = 1/2", 5/8", 11/16", 3/4"
for Threads: 1/2-13, 5/8-11, 3/4-10, 1-8

Nut Height: "G" = 3/16"
for Threads: 1/4-20, 5/16-18, 3/8-16

LOW PROFILE - STEEL & STAINLESS STEEL SOCKET

Steel	Stainless	Load	A	B	C	D	F	G
IL61-4G	IL61-4S	100	1/4-20	1/2	5/8	3/4	3/8	3/16
IL61-5G	IL61-5S	500	5/16-18	1/2	5/8	3/4	3/8	3/16
IL61-6G	IL61-6S	1000	3/8-16	1/2	5/8	3/4	3/8	3/16
IL61-7G	IL61-7S	2000	1/2-13	5/8	15/16	3/4	3/8	1/2
IL61-8G	IL61-8S	3000	5/8-11	3/4	1-1/8	3/4	1/2	5/8
IL61-9G	IL61-9S	4000	3/4-10	1	1-3/16	3/4	5/8	11/16
IL61-10G	IL61-10S	5000	1-8	1-1/4	1-1/4	3/4	11/16	3/4
IL63-4G	IL63-4S	100	1/4-20	1/2	5/8	1 1/4	3/8	3/16
IL63-5G	IL63-5S	500	5/16-18	1/2	5/8	1 1/4	3/8	3/16
IL63-6G	IL63-6S	1000	3/8-16	1/2	5/8	1 1/4	3/8	3/16
IL63-7G	IL63-7S	2000	1/2-13	5/8	15/16	1 1/4	3/8	1/2
IL63-8G	IL63-8S	3000	5/8-11	3/4	1-1/8	1 1/4	1/2	5/8
IL63-9G	IL63-9S	4000	3/4-10	1	1-3/16	1 1/4	5/8	11/16
IL63-10G	IL63-10S	5000	1-8	1-1/4	1-1/4	1 1/4	11/16	3/4
IL65-4G	IL65-4S	100	1/4-20	1/2	5/8	1 7/8	3/8	3/16
IL65-5G	IL65-5S	500	5/16-18	1/2	5/8	1 7/8	3/8	3/16
IL65-6G	IL65-6S	3000	3/8-16	1/2	5/8	1 7/8	3/8	3/16
IL65-7G	IL65-7S	5000	1/2-13	5/8	15/16	1 7/8	3/8	1/2
IL65-8G	IL65-8S	6000	5/8-11	3/4	1-1/8	1 7/8	1/2	5/8
IL65-9G	IL65-9S	8000	3/4-10	1	1-3/16	1 7/8	5/8	11/16
IL65-10G	IL65-10S	10000	1-8	1-1/4	1-1/4	1 7/8	11/16	3/4
IL67-4G	IL67-4S	100	1/4-20	1/2	5/8	2 1/2	3/8	3/16
IL67-5G	IL67-5S	500	5/16-18	1/2	5/8	2 1/2	3/8	3/16
IL67-6G	IL67-6S	3000	3/8-16	1/2	5/8	2 1/2	3/8	3/16
IL67-7G	IL67-7S	5000	1/2-13	5/8	15/16	2 1/2	3/8	1/2
IL67-8G	IL67-8S	6000	5/8-11	3/4	1-1/8	2 1/2	1/2	5/8
IL67-9G	IL67-9S	8000	3/4-10	1	1-3/16	2 1/2	5/8	11/16
IL67-10G	IL67-10S	10000	1-8	1-1/4	1-1/4	2 1/2	11/16	3/4
IL69-4G	IL69-4S	100	1/4-20	1/2	5/8	3	3/8	3/16
IL69-5G	IL69-5S	500	5/16-18	1/2	5/8	3	3/8	3/16
IL69-6G	IL69-6S	3000	3/8-16	1/2	5/8	3	3/8	3/16
IL69-7G	IL69-7S	5000	1/2-13	5/8	15/16	3	3/8	1/2
IL69-8G	IL69-8S	6000	5/8-11	3/4	1-1/8	3	1/2	5/8
IL69-9G	IL69-9S	8000	3/4-10	1	1-3/16	3	5/8	11/16
IL69-10G	IL69-10S	10000	1-8	1-1/4	1-1/4	3	11/16	3/4
IL71-4G	IL71-4S	100	1/4-20	1/2	5/8	4	3/8	3/16
IL71-5G	IL71-5S	500	5/16-18	1/2	5/8	4	3/8	3/16
IL71-6G	IL71-6S	3000	3/8-16	1/2	5/8	4	3/8	3/16
IL71-7G	IL71-7S	5000	1/2-13	5/8	15/16	4	3/8	1/2
IL71-8G	IL71-8S	6000	5/8-11	3/4	1-1/8	4	1/2	5/8
IL71-9G	IL71-9S	8000	3/4-10	1	1-3/16	4	5/8	11/16
IL71-10G	IL71-10S	10000	1-8	1-1/4	1-1/4	4	11/16	3/4

To order with 1/8" black rubber pad, (add "-P").

To order with two (2) 5/8" dia. lag holes centered at 2-3/4", (add "-H"). Only available on 4" base.



LOW PROFILE METRIC SOCKET LEVELERS

The IEC *Metric Low-Profile Socket Leveler* features an exclusive ball design that minimizes base separation. Ideal for heavy-duty load requirements. The threaded female socket allows use of your own stud or bolt. Integrated ball and swivel socket provide a low-friction support interface. Perfect for cabinets, instruments, machinery and equipment.

Features

- Steel/stainless steel options
- Integrated ball and socket
- Adjustable height
- Base adjusts 15° off centerline
- Standard gold irridite zinc finish
- Black oxide or clear chromate options
- Optional rubber pad (add -P)

Applications

- Electronic equipment
- Enclosures
- Conveyors
- Machinery
- Work tables
- Display racks

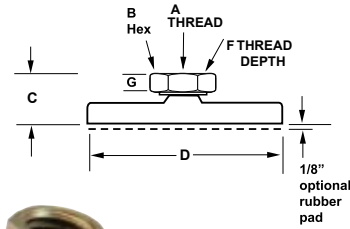

Nut Height: "G" = 1/2", 5/8", 11/16", 3/4"
for Threads: M12, M16, M20, M24



Nut Height: "G" = 3/16"
for Threads: M6, M8, M10

LOW PROFILE - METRIC STEEL & STAINLESS STEEL SOCKET

Steel	Stainless	Load	A	B	C	D	F	G
IL61-M6G	IL61-M6S	100	M6x1	1/2	5/8	3/4	3/8	3/16
IL61-M8G	IL61-M8S	500	M8x1.25	1/2	5/8	3/4	3/8	3/16
IL61-M10G	IL61-M10S	1000	M10x1.50	1/2	5/8	3/4	3/8	3/16
IL61-M12G	IL61-M12S	2000	M12x1.75	5/8	15/16	3/4	3/8	1/2
IL61-M16G	IL61-M16S	3000	M16x2.00	3/4	1-1/8	3/4	1/2	5/8
IL61-M20G	IL61-M20S	4000	M20x2.50	1	1-3/16	3/4	5/8	11/16
IL61-M24G	IL61-M24S	5000	M24x3.00	1-1/4	1-1/4	3/4	11/16	3/4
IL63-M6G	IL63-M6S	100	M6x1	1/2	5/8	1 1/4	3/8	3/16
IL63-M8G	IL63-M8S	500	M8x1.25	1/2	5/8	1 1/4	3/8	3/16
IL63-M10G	IL63-M10S	1000	M10x1.50	1/2	5/8	1 1/4	3/8	3/16
IL63-M12G	IL63-M12S	2000	M12x1.75	5/8	15/16	1 1/4	3/8	1/2
IL63-M16G	IL63-M16S	3000	M16x2.00	3/4	1-1/8	1 1/4	1/2	5/8
IL63-M20G	IL63-M20S	4000	M20x2.50	1	1-3/16	1 1/4	5/8	11/16
IL63-M24G	IL63-M24S	5000	M24x3.00	1-1/4	1-1/4	1 1/4	11/16	3/4
IL65-M6G	IL65-M6S	100	M6x1	1/2	5/8	1 7/8	3/8	3/16
IL65-M8G	IL65-M8S	500	M8x1.25	1/2	5/8	1 7/8	3/8	3/16
IL65-M10G	IL65-M10S	3000	M10x1.50	1/2	5/8	1 7/8	3/8	3/16
IL65-M12G	IL65-M12S	5000	M12x1.75	5/8	15/16	1 7/8	3/8	1/2
IL65-M16G	IL65-M16S	6000	M16x2.00	3/4	1-1/8	1 7/8	1/2	5/8
IL65-M20G	IL65-M20S	8000	M20x2.50	1	1-3/16	1 7/8	5/8	11/16
IL65-M24G	IL65-M24S	10000	M24x3.00	1-1/4	1-1/4	1 7/8	11/16	3/4
IL67-M6G	IL67-M6S	100	M6x1	1/2	5/8	2 1/2	3/8	3/16
IL67-M8G	IL67-M8S	500	M8x1.25	1/2	5/8	2 1/2	3/8	3/16
IL67-M10G	IL67-M10S	3000	M10x1.50	1/2	5/8	2 1/2	3/8	3/16
IL67-M12G	IL67-M12S	5000	M12x1.75	5/8	15/16	2 1/2	3/8	1/2
IL67-M16G	IL67-M16S	6000	M16x2.00	3/4	1-1/8	2 1/2	1/2	5/8
IL67-M20G	IL67-M20S	8000	M20x2.50	1	1-3/16	2 1/2	5/8	11/16
IL67-M24G	IL67-M24S	10000	M24x3.00	1-1/4	1-1/4	2 1/2	11/16	3/4
IL69-M6G	IL69-M6S	100	M6x1	1/2	5/8	3	3/8	3/16
IL69-M8G	IL69-M8S	500	M8x1.25	1/2	5/8	3	3/8	3/16
IL69-M10G	IL69-M10S	3000	M10x1.50	1/2	5/8	3	3/8	3/16
IL69-M12G	IL69-M12S	5000	M12x1.75	5/8	15/16	3	3/8	1/2
IL69-M16G	IL69-M16S	6000	M16x2.00	3/4	1-1/8	3	1/2	5/8
IL69-M20G	IL69-M20S	8000	M20x2.50	1	1-3/16	3	5/8	11/16
IL69-M24G	IL69-M24S	10000	M24x3.00	1-1/4	1-1/4	3	11/16	3/4
IL71-M6G	IL71-M6S	100	M6x1	1/2	5/8	4	3/8	3/16
IL71-M8G	IL71-M8S	500	M8x1.25	1/2	5/8	4	3/8	3/16
IL71-M10G	IL71-M10S	3000	M10x1.50	1/2	5/8	4	3/8	3/16
IL71-M12G	IL71-M12S	5000	M12x1.75	5/8	15/16	4	3/8	1/2
IL71-M16G	IL71-M16S	6000	M16x2.00	3/4	1-1/8	4	1/2	5/8
IL71-M20G	IL71-M20S	8000	M20x2.50	1	1-3/16	4	5/8	11/16
IL71-M24G	IL71-M24S	10000	M24x3.00	1-1/4	1-1/4	4	11/16	3/4

To order with 1/8" black rubber pad, (add "-P").

To order with two (2) 5/8" dia. lag holes centered at 2-3/4", (add "-H"). Only available on 4" base.



LOW-PROFILE STUD LEVELERS

The IEC *Low-Profile Stud Leveler* features an exclusive ball design that minimizes base separation. Ideal for heavy-duty load requirements. Integrated ball and swivel socket provide a low-friction support interface. Perfect for cabinets, instruments, machinery and equipment.

Features

- Steel/stainless steel options
- Integrated ball and stud
- Adjustable height
- Base adjusts 15° off centerline
- Standard gold irridite zinc finish
- Black oxide or clear chromate options
- Optional rubber pad (add -P)
- Non-tilt and extended stud length designs (2" - 8")
- Optional Top-A-Just™ shown at right. (add "-BR" to P/N)

Applications

- Electronic equipment
- Enclosures
- Conveyors
- Machinery
- Work tables
- Display racks

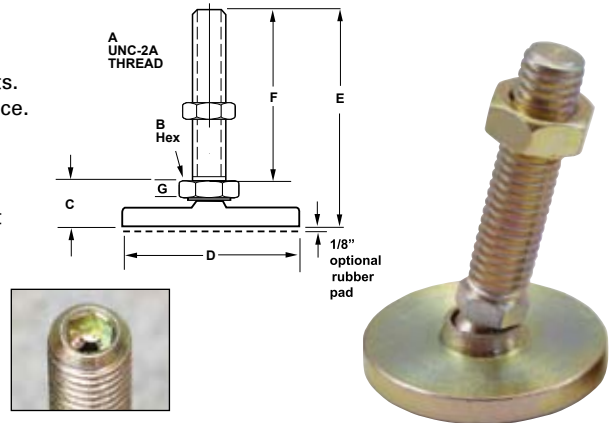

LOW PROFILE - STEEL & STAINLESS STEEL (2" STUD LENGTH)

Steel	Stainless	Load	A	B	C	D	E	F	G
IL60-4G	IL60-4S	100	1/4-20	1/2	3/4	3/4	2-3/4	2	3/16
IL60-5G	IL60-5S	500	5/16-18	1/2	3/4	3/4	2-3/4	2	3/16
IL60-6G	IL60-6S	1000	3/8-16	1/2	3/4	3/4	2-3/4	2	3/16
IL60-7G	IL60-7S	2000	1/2-13	1/2	3/4	3/4	2-3/4	2	3/16
IL60-8G	IL60-8S	3000	5/8-11	5/8	3/4	3/4	2-3/4	2	3/16
IL60-9G	IL60-9S	4000	3/4-10	3/4	3/4	3/4	2-3/4	2	3/16
IL60-10G	IL60-10S	5000	1-8	1	1	3/4	3	2	1/2
IL60-12G	IL60-12S	5000	1 1/4-7	1 1/4	1	3/4	3	2	1/2
IL62-4G	IL62-4S	100	1/4-20	1/2	3/4	1 1/4	2-3/4	2	3/16
IL62-5G	IL62-5S	500	5/16-18	1/2	3/4	1 1/4	2-3/4	2	3/16
IL62-6G	IL62-6S	1000	3/8-16	1/2	3/4	1 1/4	2-3/4	2	3/16
IL62-7G	IL62-7S	2000	1/2-13	1/2	3/4	1 1/4	2-3/4	2	3/16
IL62-8G	IL62-8S	3000	5/8-11	5/8	3/4	1 1/4	2-3/4	2	3/16
IL62-9G	IL62-9S	4000	3/4-10	3/4	3/4	1 1/4	2-3/4	2	3/16
IL62-10G	IL62-10S	5000	1-8	1	1	1 1/4	3	2	1/2
IL62-12G	IL62-12S	5000	1 1/4-7	1 1/4	1	1 1/4	3	2	1/2
IL64-4G	IL64-4S	100	1/4-20	1/2	3/4	1 7/8	2-3/4	2	3/16
IL64-5G	IL64-5S	500	5/16-18	1/2	3/4	1 7/8	2-3/4	2	3/16
IL64-6G	IL64-6S	3000	3/8-16	1/2	3/4	1 7/8	2-3/4	2	3/16
IL64-7G	IL64-7S	5000	1/2-13	1/2	3/4	1 7/8	2-3/4	2	3/16
IL64-8G	IL64-8S	6000	5/8-11	5/8	3/4	1 7/8	2-3/4	2	3/16
IL64-9G	IL64-9S	8000	3/4-10	3/4	3/4	1 7/8	2-3/4	2	3/16
IL64-10G	IL64-10S	10000	1-8	1	1	1 7/8	3	2	1/2
IL64-12G	IL64-12S	10000	1 1/4-7	1 1/4	1	1 7/8	3	2	1/2
IL66-4G	IL66-4S	100	1/4-20	1/2	3/4	2 1/2	2-3/4	2	3/16
IL66-5G	IL66-5S	500	5/16-18	1/2	3/4	2 1/2	2-3/4	2	3/16
IL66-6G	IL66-6S	3000	3/8-16	1/2	3/4	2 1/2	2-3/4	2	3/16
IL66-7G	IL66-7S	5000	1/2-13	1/2	3/4	2 1/2	2-3/4	2	3/16
IL66-8G	IL66-8S	6000	5/8-11	5/8	3/4	2 1/2	2-3/4	2	3/16
IL66-9G	IL66-9S	8000	3/4-10	3/4	3/4	2 1/2	2-3/4	2	3/16
IL66-10G	IL66-10S	10000	1-8	1	1	2 1/2	3	2	1/2
IL66-12G	IL66-12S	10000	1 1/4-7	1 1/4	1	2 1/2	3	2	1/2
IL68-4G	IL68-4S	100	1/4-20	1/2	3/4	3	2-3/4	2	3/16
IL68-5G	IL68-5S	500	5/16-18	1/2	3/4	3	2-3/4	2	3/16
IL68-6G	IL68-6S	3000	3/8-16	1/2	3/4	3	2-3/4	2	3/16
IL68-7G	IL68-7S	5000	1/2-13	1/2	3/4	3	2-3/4	2	3/16
IL68-8G	IL68-8S	6000	5/8-11	5/8	3/4	3	2-3/4	2	3/16
IL68-9G	IL68-9S	8000	3/4-10	3/4	3/4	3	2-3/4	2	3/16
IL68-10G	IL68-10S	10000	1-8	1	1	3	3	2	1/2
IL68-12G	IL68-12S	10000	1 1/4-7	1 1/4	1	3	3	2	1/2
IL70-4G	IL70-4S	100	1/4-20	1/2	3/4	4	2-3/4	2	3/16
IL70-5G	IL70-5S	500	5/16-18	1/2	3/4	4	2-3/4	2	3/16
IL70-6G	IL70-6S	3000	3/8-16	1/2	3/4	4	2-3/4	2	3/16
IL70-7G	IL70-7S	5000	1/2-13	1/2	3/4	4	2-3/4	2	3/16
IL70-8G	IL70-8S	6000	5/8-11	5/8	3/4	4	2-3/4	2	3/16
IL70-9G	IL70-9S	8000	3/4-10	3/4	3/4	4	2-3/4	2	3/16
IL70-10G	IL70-10S	10000	1-8	1	1	4	3	2	1/2
IL70-12G	IL70-12S	10000	1 1/4-7	1 1/4	1	4	3	2	1/2

To order with 1/8" black rubber pad, (add "-P"). To order optional top broached hex, "allen drive," add "-BR". To order with two (2) 5/8" dia. lag holes centered at 2-3/4", (add "-H"). Only available on 4" base.

Top Hex (Allen-drive) Thread & Hex Size								
Thread	1/4-20	5/16-18	3/8-16	1/2-13	5/8-11	3/4-10	1-8	1-1/4-7
Hex Size	1/8	5/32	3/16	1/4	5/16	3/8	9/16	5/8



LOW-PROFILE STUD LEVELERS

The IEC *Low-Profile Stud Leveler* features an exclusive ball design that minimizes base separation. Ideal for heavy-duty load requirements. Integrated ball and swivel socket provide a low-friction support interface. Perfect for cabinets, instruments, machinery and equipment.

Features

- Steel/stainless steel options
- Integrated ball and stud
- Adjustable height
- Base adjusts 15° off centerline
- Standard gold irridite zinc finish
- Black oxide or clear chromate options
- Optional rubber pad (add -P)
- Non-tilt and extended stud length designs (2" - 8")
- Optional Top-A-Just™ shown at right. (add "-BR" to P/N)

Applications

- Electronic equipment
- Enclosures
- Conveyors
- Machinery
- Work tables
- Display racks

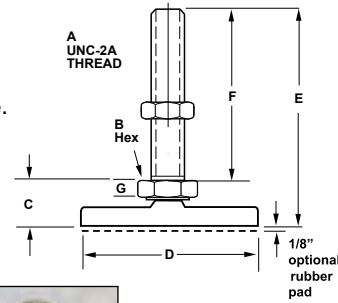

LOW PROFILE - STEEL & STAINLESS STEEL (3" STUD LENGTH)

Steel	Stainless	Load	A	B	C	D	E	F	G
IL60-4Gx3	IL60-4Sx3	100	1/4-20	1/2	3/4	3/4	3-3/4	3	3/16
IL60-5Gx3	IL60-5Sx3	500	5/16-18	1/2	3/4	3/4	3-3/4	3	3/16
IL60-6Gx3	IL60-6Sx3	1000	3/8-16	1/2	3/4	3/4	3-3/4	3	3/16
IL60-7Gx3	IL60-7Sx3	2000	1/2-13	1/2	3/4	3/4	3-3/4	3	3/16
IL60-8Gx3	IL60-8Sx3	3000	5/8-11	5/8	3/4	3/4	3-3/4	3	3/16
IL60-9Gx3	IL60-9Sx3	4000	3/4-10	3/4	3/4	3/4	3-3/4	3	3/16
IL60-10Gx3	IL60-10Sx3	5000	1-8	1	1	3/4	4	3	1/2
IL60-12Gx3	IL60-12Sx3	5000	1 1/4-7	1 1/4	1	3/4	4	3	1/2
IL62-4Gx3	IL62-4Sx3	100	1/4-20	1/2	3/4	1 1/4	3-3/4	3	3/16
IL62-5Gx3	IL62-5Sx3	500	5/16-18	1/2	3/4	1 1/4	3-3/4	3	3/16
IL62-6Gx3	IL62-6Sx3	1000	3/8-16	1/2	3/4	1 1/4	3-3/4	3	3/16
IL62-7Gx3	IL62-7Sx3	2000	1/2-13	1/2	3/4	1 1/4	3-3/4	3	3/16
IL62-8Gx3	IL62-8Sx3	3000	5/8-11	5/8	3/4	1 1/4	3-3/4	3	3/16
IL62-9Gx3	IL62-9Sx3	4000	3/4-10	3/4	3/4	1 1/4	3-3/4	3	3/16
IL62-10Gx3	IL62-10Sx3	5000	1-8	1	1	1 1/4	4	3	1/2
IL62-12Gx3	IL62-12Sx3	5000	1 1/4-7	1 1/4	1	1 1/4	4	3	1/2
IL64-4Gx3	IL64-4Sx3	100	1/4-20	1/2	3/4	1 7/8	3-3/4	3	3/16
IL64-5Gx3	IL64-5Sx3	500	5/16-18	1/2	3/4	1 7/8	3-3/4	3	3/16
IL64-6Gx3	IL64-6Sx3	3000	3/8-16	1/2	3/4	1 7/8	3-3/4	3	3/16
IL64-7Gx3	IL64-7Sx3	5000	1/2-13	1/2	3/4	1 7/8	3-3/4	3	3/16
IL64-8Gx3	IL64-8Sx3	6000	5/8-11	5/8	3/4	1 7/8	3-3/4	3	3/16
IL64-9Gx3	IL64-9Sx3	8000	3/4-10	3/4	3/4	1 7/8	3-3/4	3	3/16
IL64-10Gx3	IL64-10Sx3	10000	1-8	1	1	1 7/8	4	3	1/2
IL64-12Gx3	IL64-12Sx3	10000	1 1/4-7	1 1/4	1	1 7/8	4	3	1/2
IL66-4Gx3	IL66-4Sx3	100	1/4-20	1/2	3/4	2 1/2	3-3/4	3	3/16
IL66-5Gx3	IL66-5Sx3	500	5/16-18	1/2	3/4	2 1/2	3-3/4	3	3/16
IL66-6Gx3	IL66-6Sx3	3000	3/8-16	1/2	3/4	2 1/2	3-3/4	3	3/16
IL66-7Gx3	IL66-7Sx3	5000	1/2-13	1/2	3/4	2 1/2	3-3/4	3	3/16
IL66-8Gx3	IL66-8Sx3	6000	5/8-11	5/8	3/4	2 1/2	3-3/4	3	3/16
IL66-9Gx3	IL66-9Sx3	8000	3/4-10	3/4	3/4	2 1/2	3-3/4	3	3/16
IL66-10Gx3	IL66-10Sx3	10000	1-8	1	1	2 1/2	4	3	1/2
IL66-12Gx3	IL66-12Sx3	10000	1 1/4-7	1 1/4	1	2 1/2	4	3	1/2
IL68-4Gx3	IL68-4Sx3	100	1/4-20	1/2	3/4	3	3-3/4	3	3/16
IL68-5Gx3	IL68-5Sx3	500	5/16-18	1/2	3/4	3	3-3/4	3	3/16
IL68-6Gx3	IL68-6Sx3	3000	3/8-16	1/2	3/4	3	3-3/4	3	3/16
IL68-7Gx3	IL68-7Sx3	5000	1/2-13	1/2	3/4	3	3-3/4	3	3/16
IL68-8Gx3	IL68-8Sx3	6000	5/8-11	5/8	3/4	3	3-3/4	3	3/16
IL68-9Gx3	IL68-9Sx3	8000	3/4-10	3/4	3/4	3	3-3/4	3	3/16
IL68-10Gx3	IL68-10Sx3	10000	1-8	1	1	3	4	3	1/2
IL68-12Gx3	IL68-12Sx3	10000	1 1/4-7	1 1/4	1	3	4	3	1/2
IL70-4Gx3	IL70-4Sx3	100	1/4-20	1/2	3/4	4	3-3/4	3	3/16
IL70-5Gx3	IL70-5Sx3	500	5/16-18	1/2	3/4	4	3-3/4	3	3/16
IL70-6Gx3	IL70-6Sx3	3000	3/8-16	1/2	3/4	4	3-3/4	3	3/16
IL70-7Gx3	IL70-7Sx3	5000	1/2-13	1/2	3/4	4	3-3/4	3	3/16
IL70-8Gx3	IL70-8Sx3	6000	5/8-11	5/8	3/4	4	3-3/4	3	3/16
IL70-9Gx3	IL70-9Sx3	8000	3/4-10	3/4	3/4	4	3-3/4	3	3/16
IL70-10Gx3	IL70-10Sx3	10000	1-8	1	1	4	4	3	1/2
IL70-12Gx3	IL70-12Sx3	10000	1 1/4-7	1 1/4	1	4	4	3	1/2

To order with 1/8" black rubber pad, (add "-P"). To order optional top broached hex, "allen drive," add "-BR". To order with two (2) 5/8" dia. lag holes centered at 2-3/4", (add "-H"). Only available on 4" base.

Top Hex (Allen-drive) Thread & Hex Size							
Thread	1/4-20	5/16-18	3/8-16	1/2-13	5/8-11	3/4-10	1-8
Hex Size	1/8	5/32	3/16	1/4	5/16	3/8	9/16



LOW-PROFILE STUD LEVELERS

The IEC *Low-Profile Stud Leveler* features an exclusive ball design that minimizes base separation. Ideal for heavy-duty load requirements. Integrated ball and swivel socket provide a low-friction support interface. Perfect for cabinets, instruments, machinery and equipment.

Features

- Steel/stainless steel options
- Integrated ball and stud
- Adjustable height
- Base adjusts 15° off centerline
- Standard gold irridite zinc finish
- Black oxide or clear chromate options
- Optional rubber pad (add -P)
- Non-tilt and extended stud length designs (2" - 8")
- Optional Top-A-Just™ shown at right. (add "-BR" to P/N)

Applications

- Electronic equipment
- Enclosures
- Conveyors
- Machinery
- Work tables
- Display racks

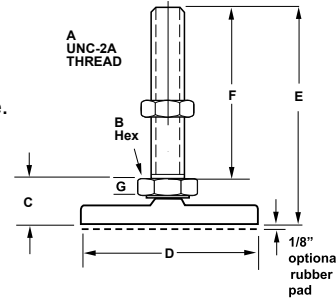

LOW PROFILE - STEEL & STAINLESS STEEL (4" STUD LENGTH)

Steel	Stainless	Load	A	B	C	D	E	F	G
IL60-5Gx4	IL60-5Sx4	500	5/16-18	1/2	3/4	3/4	4-3/4	4	3/16
IL60-6Gx4	IL60-6Sx4	1000	3/8-16	1/2	3/4	3/4	4-3/4	4	3/16
IL60-7Gx4	IL60-7Sx4	2000	1/2-13	1/2	3/4	3/4	4-3/4	4	3/16
IL60-8Gx4	IL60-8Sx4	3000	5/8-11	5/8	3/4	3/4	4-3/4	4	3/16
IL60-9Gx4	IL60-9Sx4	4000	3/4-10	3/4	3/4	3/4	4-3/4	4	3/16
IL60-10Gx4	IL60-10Sx4	5000	1-8	1	1	3/4	5	4	1/2
IL60-12Gx4	IL60-12Sx4	5000	1 1/4-7	1 1/4	1	3/4	5	4	1/2
IL62-5Gx4	IL62-5Sx4	500	5/16-18	1/2	3/4	1 1/4	4-3/4	4	3/16
IL62-6Gx4	IL62-6Sx4	1000	3/8-16	1/2	3/4	1 1/4	4-3/4	4	3/16
IL62-7Gx4	IL62-7Sx4	2000	1/2-13	1/2	3/4	1 1/4	4-3/4	4	3/16
IL62-8Gx4	IL62-8Sx4	3000	5/8-11	5/8	3/4	1 1/4	4-3/4	4	3/16
IL62-9Gx4	IL62-9Sx4	4000	3/4-10	3/4	3/4	1 1/4	4-3/4	4	3/16
IL62-10Gx4	IL62-10Sx4	5000	1-8	1	1	1 1/4	5	4	1/2
IL62-12Gx4	IL62-12Sx4	5000	1 1/4-7	1 1/4	1	1 1/4	5	4	1/2
IL64-5Gx4	IL64-5Sx4	500	5/16-18	1/2	3/4	1 7/8	4-3/4	4	3/16
IL64-6Gx4	IL64-6Sx4	3000	3/8-16	1/2	3/4	1 7/8	4-3/4	4	3/16
IL64-7Gx4	IL64-7Sx4	5000	1/2-13	1/2	3/4	1 7/8	4-3/4	4	3/16
IL64-8Gx4	IL64-8Sx4	6000	5/8-11	5/8	3/4	1 7/8	4-3/4	4	3/16
IL64-9Gx4	IL64-9Sx4	8000	3/4-10	3/4	3/4	1 7/8	4-3/4	4	3/16
IL64-10Gx4	IL64-10Sx4	10000	1-8	1	1	1 7/8	5	4	1/2
IL64-12Gx4	IL64-12Sx4	10000	1 1/4-7	1 1/4	1	1 7/8	5	4	1/2
IL66-5Gx4	IL66-5Sx4	500	5/16-18	1/2	3/4	2 1/2	4-3/4	4	3/16
IL66-6Gx4	IL66-6Sx4	3000	3/8-16	1/2	3/4	2 1/2	4-3/4	4	3/16
IL66-7Gx4	IL66-7Sx4	5000	1/2-13	1/2	3/4	2 1/2	4-3/4	4	3/16
IL66-8Gx4	IL66-8Sx4	6000	5/8-11	5/8	3/4	2 1/2	4-3/4	4	3/16
IL66-9Gx4	IL66-9Sx4	8000	3/4-10	3/4	3/4	2 1/2	4-3/4	4	3/16
IL66-10Gx4	IL66-10Sx4	10000	1-8	1	1	2 1/2	5	4	1/2
IL66-12Gx4	IL66-12Sx4	10000	1 1/4-7	1 1/4	1	2 1/2	5	4	1/2
IL68-5Gx4	IL68-5Sx4	500	5/16-18	1/2	3/4	3	4-3/4	4	3/16
IL68-6Gx4	IL68-6Sx4	3000	3/8-16	1/2	3/4	3	4-3/4	4	3/16
IL68-7Gx4	IL68-7Sx4	5000	1/2-13	1/2	3/4	3	4-3/4	4	3/16
IL68-8Gx4	IL68-8Sx4	6000	5/8-11	5/8	3/4	3	4-3/4	4	3/16
IL68-9Gx4	IL68-9Sx4	8000	3/4-10	3/4	3/4	3	4-3/4	4	3/16
IL68-10Gx4	IL68-10Sx4	10000	1-8	1	1	3	5	4	1/2
IL68-12Gx4	IL68-12Sx4	10000	1 1/4-7	1 1/4	1	3	5	4	1/2
IL70-5Gx4	IL70-5Sx4	500	5/16-18	1/2	3/4	4	4-3/4	4	3/16
IL70-6Gx4	IL70-6Sx4	3000	3/8-16	1/2	3/4	4	4-3/4	4	3/16
IL70-7Gx4	IL70-7Sx4	5000	1/2-13	1/2	3/4	4	4-3/4	4	3/16
IL70-8Gx4	IL70-8Sx4	6000	5/8-11	5/8	3/4	4	4-3/4	4	3/16
IL70-9Gx4	IL70-9Sx4	8000	3/4-10	3/4	3/4	4	4-3/4	4	3/16
IL70-10Gx4	IL70-10Sx4	10000	1-8	1	1	4	5	4	1/2
IL70-12Gx4	IL70-12Sx4	10000	1 1/4-7	1 1/4	1	4	5	4	1/2

To order with 1/8" black rubber pad, (add "-P"). To order optional top broached hex, "allen drive," add "-BR". To order with two (2) 5/8" dia. lag holes centered at 2-3/4", (add "-H"). Only available on 4" base.

Top Hex (Allen-drive) Thread & Hex Size								
Thread	1/4-20	5/16-18	3/8-16	1/2-13	5/8-11	3/4-10	1-8	1-1/4-7
Hex Size	1/8	5/32	3/16	1/4	5/16	3/8	9/16	5/8



LOW-PROFILE STUD LEVELERS

The IEC *Low-Profile Stud Leveler* features an exclusive ball design that minimizes base separation. Ideal for heavy-duty load requirements. Integrated ball and swivel socket provide a low-friction support interface. Perfect for cabinets, instruments, machinery and equipment.

Features

- Steel/stainless steel options
- Integrated ball and stud
- Adjustable height
- Base adjusts 15° off centerline
- Standard gold irridite zinc finish
- Black oxide or clear chromate options
- Optional rubber pad (add -P)
- Non-tilt and extended stud length designs (2" - 8")
- Optional Top-A-Just™ shown at right. (add "-BR" to P/N)

Applications

- Electronic equipment
- Enclosures
- Conveyors
- Machinery
- Work tables
- Display racks

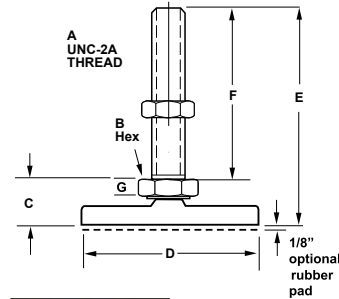

LOW PROFILE - STEEL & STAINLESS STEEL (5" STUD LENGTH)

Steel	Stainless	Load	A	B	C	D	E	F	G
IL60-6Gx5	IL60-6Sx5	1000	3/8-16	1/2	3/4	3/4	5-3/4	5	3/16
IL60-7Gx5	IL60-7Sx5	2000	1/2-13	1/2	3/4	3/4	5-3/4	5	3/16
IL60-8Gx5	IL60-8Sx5	3000	5/8-11	5/8	3/4	3/4	5-3/4	5	3/16
IL60-9Gx5	IL60-9Sx5	4000	3/4-10	3/4	3/4	3/4	5-3/4	5	3/16
IL60-10Gx5	IL60-10Sx5	5000	1-8	1	1	3/4	6	5	1/2
IL60-12Gx5	IL60-12Sx5	5000	1 1/4-7	1 1/4	1	3/4	6	5	1/2
IL62-6Gx5	IL62-6Sx5	1000	3/8-16	1/2	3/4	1 1/4	5-3/4	5	3/16
IL62-7Gx5	IL62-7Sx5	2000	1/2-13	1/2	3/4	1 1/4	5-3/4	5	3/16
IL62-8Gx5	IL62-8Sx5	3000	5/8-11	5/8	3/4	1 1/4	5-3/4	5	3/16
IL62-9Gx5	IL62-9Sx5	4000	3/4-10	3/4	3/4	1 1/4	5-3/4	5	3/16
IL62-10Gx5	IL62-10Sx5	5000	1-8	1	1	1 1/4	6	5	1/2
IL62-12Gx5	IL62-12Sx5	5000	1 1/4-7	1 1/4	1	1 1/4	6	5	1/2
IL64-6Gx5	IL64-6Sx5	3000	3/8-16	1/2	3/4	1 7/8	5-3/4	5	3/16
IL64-7Gx5	IL64-7Sx5	5000	1/2-13	1/2	3/4	1 7/8	5-3/4	5	3/16
IL64-8Gx5	IL64-8Sx5	6000	5/8-11	5/8	3/4	1 7/8	5-3/4	5	3/16
IL64-9Gx5	IL64-9Sx5	8000	3/4-10	3/4	3/4	1 7/8	5-3/4	5	3/16
IL64-10Gx5	IL64-10Sx5	10000	1-8	1	1	1 7/8	6	5	1/2
IL64-12Gx5	IL64-12Sx5	10000	1 1/4-7	1 1/4	1	1 7/8	6	5	1/2
IL66-6Gx5	IL66-6Sx5	3000	3/8-16	1/2	3/4	2 1/2	5-3/4	5	3/16
IL66-7Gx5	IL66-7Sx5	5000	1/2-13	1/2	3/4	2 1/2	5-3/4	5	3/16
IL66-8Gx5	IL66-8Sx5	6000	5/8-11	5/8	3/4	2 1/2	5-3/4	5	3/16
IL66-9Gx5	IL66-9Sx5	8000	3/4-10	3/4	3/4	2 1/2	5-3/4	5	3/16
IL66-10Gx5	IL66-10Sx5	10000	1-8	1	1	2 1/2	6	5	1/2
IL66-12Gx5	IL66-12Sx5	10000	1 1/4-7	1 1/4	1	2 1/2	6	5	1/2
IL68-6Gx5	IL68-6Sx5	3000	3/8-16	1/2	3/4	3	5-3/4	5	3/16
IL68-7Gx5	IL68-7Sx5	5000	1/2-13	1/2	3/4	3	5-3/4	5	3/16
IL68-8Gx5	IL68-8Sx5	6000	5/8-11	5/8	3/4	3	5-3/4	5	3/16
IL68-9Gx5	IL68-9Sx5	8000	3/4-10	3/4	3/4	3	5-3/4	5	3/16
IL68-10Gx5	IL68-10Sx5	10000	1-8	1	1	3	6	5	1/2
IL68-12Gx5	IL68-12Sx5	10000	1 1/4-7	1 1/4	1	3	6	5	1/2
IL70-6Gx5	IL70-6Sx5	3000	3/8-16	1/2	3/4	4	5-3/4	5	3/16
IL70-7Gx5	IL70-7Sx5	5000	1/2-13	1/2	3/4	4	5-3/4	5	3/16
IL70-8Gx5	IL70-8Sx5	6000	5/8-11	5/8	3/4	4	5-3/4	5	3/16
IL70-9Gx5	IL70-9Sx5	8000	3/4-10	3/4	3/4	4	5-3/4	5	3/16
IL70-10Gx5	IL70-10Sx5	10000	1-8	1	1	4	6	5	1/2
IL70-12Gx5	IL70-12Sx5	10000	1 1/4-7	1 1/4	1	4	6	5	1/2

To order with 1/8" black rubber pad, (add "-P"). To order optional top broached hex, "allen drive," add "-BR".
 To order with two (2) 5/8" dia. lag holes centered at 2-3/4", (add "-H"). Only available on 4" base.

Top Hex (Allen-drive) Thread & Hex Size								
Thread	1/4-20	5/16-18	3/8-16	1/2-13	5/8-11	3/4-10	1-8	1-1/4-7
Hex Size	1/8	5/32	3/16	1/4	5/16	3/8	9/16	5/8



LOW-PROFILE STUD LEVELERS

The IEC *Low-Profile Stud Leveler* features an exclusive ball design that minimizes base separation. Ideal for heavy-duty load requirements. Integrated ball and swivel socket provide a low-friction support interface. Perfect for cabinets, instruments, machinery and equipment.

Features

- Steel/stainless steel options
- Integrated ball and stud
- Adjustable height
- Base adjusts 15° off centerline
- Standard gold irridite zinc finish
- Black oxide or clear chromate options
- Optional rubber pad (add -P)
- Non-tilt and extended stud length designs (2" - 8")
- Optional Top-A-Just™ shown at right. (add "-BR" to P/N)

Applications

- Electronic equipment
- Enclosures
- Conveyors
- Machinery
- Work tables
- Display racks

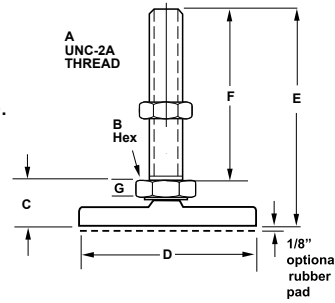

LOW PROFILE - STEEL & STAINLESS STEEL (6" STUD LENGTH)

Steel	Stainless	Load	A	B	C	D	E	F	G
IL60-6Gx6	IL60-6Sx6	1000	3/8-16	1/2	3/4	3/4	6-3/4	6	3/16
IL60-7Gx6	IL60-7Sx6	2000	1/2-13	1/2	3/4	3/4	6-3/4	6	3/16
IL60-8Gx6	IL60-8Sx6	3000	5/8-11	5/8	3/4	3/4	6-3/4	6	3/16
IL60-9Gx6	IL60-9Sx6	4000	3/4-10	3/4	3/4	3/4	6-3/4	6	3/16
IL60-10Gx6	IL60-10Sx6	5000	1-8	1	1	3/4	7	6	1/2
IL60-12Gx6	IL60-12Sx6	5000	1 1/4-7	1 1/4	1	3/4	7	6	1/2
IL62-6Gx6	IL62-6Sx6	1000	3/8-16	1/2	3/4	1 1/4	6-3/4	6	3/16
IL62-7Gx6	IL62-7Sx6	2000	1/2-13	1/2	3/4	1 1/4	6-3/4	6	3/16
IL62-8Gx6	IL62-8Sx6	3000	5/8-11	5/8	3/4	1 1/4	6-3/4	6	3/16
IL62-9Gx6	IL62-9Sx6	4000	3/4-10	3/4	3/4	1 1/4	6-3/4	6	3/16
IL62-10Gx6	IL62-10Sx6	5000	1-8	1	1	1 1/4	7	6	1/2
IL62-12Gx6	IL62-12Sx6	5000	1 1/4-7	1 1/4	1	1 1/4	7	6	1/2
IL64-6Gx6	IL64-6Sx6	3000	3/8-16	1/2	3/4	1 7/8	6-3/4	6	3/16
IL64-7Gx6	IL64-7Sx6	5000	1/2-13	1/2	3/4	1 7/8	6-3/4	6	3/16
IL64-8Gx6	IL64-8Sx6	6000	5/8-11	5/8	3/4	1 7/8	6-3/4	6	3/16
IL64-9Gx6	IL64-9Sx6	8000	3/4-10	3/4	3/4	1 7/8	6-3/4	6	3/16
IL64-10Gx6	IL64-10Sx6	10000	1-8	1	1	1 7/8	7	6	1/2
IL64-12Gx6	IL64-12Sx6	10000	1 1/4-7	1 1/4	1	1 7/8	7	6	1/2
IL66-6Gx6	IL66-6Sx6	3000	3/8-16	1/2	3/4	2 1/2	6-3/4	6	3/16
IL66-7Gx6	IL66-7Sx6	5000	1/2-13	1/2	3/4	2 1/2	6-3/4	6	3/16
IL66-8Gx6	IL66-8Sx6	6000	5/8-11	5/8	3/4	2 1/2	6-3/4	6	3/16
IL66-9Gx6	IL66-9Sx6	8000	3/4-10	3/4	3/4	2 1/2	6-3/4	6	3/16
IL66-10Gx6	IL66-10Sx6	10000	1-8	1	1	2 1/2	7	6	1/2
IL66-12Gx6	IL66-12Sx6	10000	1 1/4-7	1 1/4	1	2 1/2	7	6	1/2
IL68-6Gx6	IL68-6Sx6	3000	3/8-16	1/2	3/4	3	6-3/4	6	3/16
IL68-7Gx6	IL68-7Sx6	5000	1/2-13	1/2	3/4	3	6-3/4	6	3/16
IL68-8Gx6	IL68-8Sx6	6000	5/8-11	5/8	3/4	3	6-3/4	6	3/16
IL68-9Gx6	IL68-9Sx6	8000	3/4-10	3/4	3/4	3	6-3/4	6	3/16
IL68-10Gx6	IL68-10Sx6	10000	1-8	1	1	3	7	6	1/2
IL68-12Gx6	IL68-12Sx6	10000	1 1/4-7	1 1/4	1	3	7	6	1/2
IL70-6Gx6	IL70-6Sx6	3000	3/8-16	1/2	3/4	4	6-3/4	6	3/16
IL70-7Gx6	IL70-7Sx6	5000	1/2-13	1/2	3/4	4	6-3/4	6	3/16
IL70-8Gx6	IL70-8Sx6	6000	5/8-11	5/8	3/4	4	6-3/4	6	3/16
IL70-9Gx6	IL70-9Sx6	8000	3/4-10	3/4	3/4	4	6-3/4	6	3/16
IL70-10Gx6	IL70-10Sx6	10000	1-8	1	1	4	7	6	1/2
IL70-12Gx6	IL70-12Sx6	10000	1 1/4-7	1 1/4	1	4	7	6	1/2

To order with 1/8" black rubber pad, (add "-P"). To order optional top broached hex, "allen drive," add "-BR".
 To order with two (2) 5/8" dia. lag holes centered at 2-3/4", (add "-H"). Only available on 4" base.

Top Hex (Allen-drive) Thread & Hex Size								
Thread	1/4-20	5/16-18	3/8-16	1/2-13	5/8-11	3/4-10	1-8	1-1/4-7
Hex Size	1/8	5/32	3/16	1/4	5/16	3/8	9/16	5/8



LOW-PROFILE STUD LEVELERS

The IEC *Low-Profile Stud Leveler* features an exclusive ball design that minimizes base separation. Ideal for heavy-duty load requirements. Integrated ball and swivel socket provide a low-friction support interface. Perfect for cabinets, instruments, machinery and equipment.

Features

- Steel/stainless steel options
- Integrated ball and stud
- Adjustable height
- Base adjusts 15° off centerline
- Standard gold irridite zinc finish
- Black oxide or clear chromate options
- Optional rubber pad (add -P)
- Non-tilt and extended stud length designs (2" - 8")
- Optional Top-A-Just™ shown at right. (add "-BR" to P/N)

Applications

- Electronic equipment
- Enclosures
- Conveyors
- Machinery
- Work tables
- Display racks

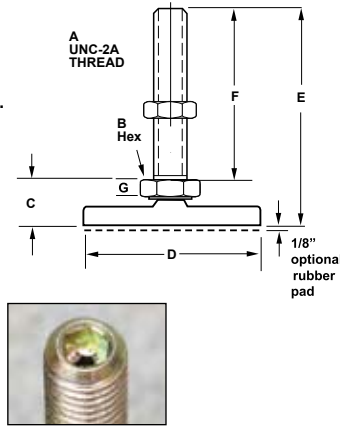

LOW PROFILE - STEEL & STAINLESS STEEL (8" STUD LENGTH)

Steel	Stainless	Load	A	B	C	D	E	F	G
IL60-7Gx8	IL60-7Sx8	2000	1/2-13	1/2	3/4	3/4	8-3/4	8	3/16
IL60-8Gx8	IL60-8Sx8	3000	5/8-11	5/8	3/4	3/4	8-3/4	8	3/16
IL60-9Gx8	IL60-9Sx8	4000	3/4-10	3/4	3/4	3/4	8-3/4	8	3/16
IL60-10Gx8	IL60-10Sx8	5000	1-8	1	1	3/4	9	8	1/2
IL60-12Gx8	IL60-12Sx8	5000	1 1/4-7	1 1/4	1	3/4	9	8	1/2
IL62-7Gx8	IL62-7Sx8	2000	1/2-13	1/2	3/4	1 1/4	8-3/4	8	3/16
IL62-8Gx8	IL62-8Sx8	3000	5/8-11	5/8	3/4	1 1/4	8-3/4	8	3/16
IL62-9Gx8	IL62-9Sx8	4000	3/4-10	3/4	3/4	1 1/4	8-3/4	8	3/16
IL62-10Gx8	IL62-10Sx8	5000	1-8	1	1	1 1/4	9	8	1/2
IL62-12Gx8	IL62-12Sx8	5000	1 1/4-7	1 1/4	1	1 1/4	9	8	1/2
IL64-7Gx8	IL64-7Sx8	5000	1/2-13	1/2	3/4	1 7/8	8-3/4	8	3/16
IL64-8Gx8	IL64-8Sx8	6000	5/8-11	5/8	3/4	1 7/8	8-3/4	8	3/16
IL64-9Gx8	IL64-9Sx8	8000	3/4-10	3/4	3/4	1 7/8	8-3/4	8	3/16
IL64-10Gx8	IL64-10Sx8	10000	1-8	1	1	1 7/8	9	8	1/2
IL64-12Gx8	IL64-12Sx8	10000	1 1/4-7	1 1/4	1	1 7/8	9	8	1/2
IL66-7Gx8	IL66-7Sx8	5000	1/2-13	1/2	3/4	2 1/2	8-3/4	8	3/16
IL66-8Gx8	IL66-8Sx8	6000	5/8-11	5/8	3/4	2 1/2	8-3/4	8	3/16
IL66-9Gx8	IL66-9Sx8	8000	3/4-10	3/4	3/4	2 1/2	8-3/4	8	3/16
IL66-10Gx8	IL66-10Sx8	10000	1-8	1	1	2 1/2	9	8	1/2
IL66-12Gx8	IL66-12Sx8	10000	1 1/4-7	1 1/4	1	2 1/2	9	8	1/2
IL68-7Gx8	IL68-7Sx8	5000	1/2-13	1/2	3/4	3	8-3/4	8	3/16
IL68-8Gx8	IL68-8Sx8	6000	5/8-11	5/8	3/4	3	8-3/4	8	3/16
IL68-9Gx8	IL68-9Sx8	8000	3/4-10	3/4	3/4	3	8-3/4	8	3/16
IL68-10Gx8	IL68-10Sx8	10000	1-8	1	1	3	9	8	1/2
IL68-12Gx8	IL68-12Sx8	10000	1 1/4-7	1 1/4	1	3	9	8	1/2
IL70-7Gx8	IL70-7Sx8	5000	1/2-13	1/2	3/4	4	8-3/4	8	3/16
IL70-8Gx8	IL70-8Sx8	6000	5/8-11	5/8	3/4	4	8-3/4	8	3/16
IL70-9Gx8	IL70-9Sx8	8000	3/4-10	3/4	3/4	4	8-3/4	8	3/16
IL70-10Gx8	IL70-10Sx8	10000	1-8	1	1	4	9	8	1/2
IL70-12Gx8	IL70-12Sx8	10000	1 1/4-7	1 1/4	1	4	9	8	1/2

To order with 1/8" black rubber pad, (add "-P"). To order optional top broached hex, "allen drive," add "-BR". To order with two (2) 5/8" dia. lag holes centered at 2-3/4", (add "-H"). Only available on 4" base.

Top Hex (Allen-drive) Thread & Hex Size								
Thread	1/4-20	5/16-18	3/8-16	1/2-13	5/8-11	3/4-10	1-8	1-1/4-7
Hex Size	1/8	5/32	3/16	1/4	5/16	3/8	9/16	5/8



LOW-PROFILE METRIC STUD LEVELERS

The IEC *Metric Low-Profile Stud Leveler* features an exclusive ball design that minimizes base separation. Ideal for heavy-duty load requirements. Integrated ball and swivel socket provide a low-friction support interface. Perfect for cabinets, instruments, machinery and equipment.

Features

- Steel/stainless steel options
- Integrated ball and stud
- Adjustable height
- Base adjusts 15° off centerline
- Standard gold irridite zinc finish
- Black oxide or clear chromate options
- Optional rubber pad (add -P)
- Non-tilt and extended stud length designs (2" - 8")
- Optional Top-A-Just™ shown at right. (add "-BR" to P/N)

Applications

- Electronic equipment
- Enclosures
- Conveyors
- Machinery
- Work tables
- Display racks

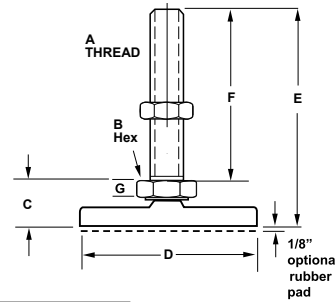

LOW PROFILE - METRIC STEEL & STAINLESS STEEL (2" STUD)

Steel	Stainless	Load	A	B	C	D	E	F	G
IL60-M6G	IL60-M6S	100	M6x1	1/2	3/4	3/4	2-3/4	2	3/16
IL60-M8G	IL60-M8S	500	M8x1.25	1/2	3/4	3/4	2-3/4	2	3/16
IL60-M10G	IL60-M10S	1000	M10x1.50	1/2	3/4	3/4	2-3/4	2	3/16
IL60-M12G	IL60-M12S	2000	M12x1.75	1/2	3/4	3/4	2-3/4	2	3/16
IL60-M16G	IL60-M16S	3000	M16x2.00	5/8	3/4	3/4	2-3/4	2	3/16
IL60-M20G	IL60-M20S	4000	M20x2.50	3/4	3/4	3/4	2-3/4	2	3/16
IL60-M24G	IL60-M24S	5000	M24x3.00	1	1	3/4	3	2	1/2
IL62-M6G	IL62-M6S	100	M6x1	1/2	3/4	1 1/4	2-3/4	2	3/16
IL62-M8G	IL62-M8S	500	M8x1.25	1/2	3/4	1 1/4	2-3/4	2	3/16
IL62-M10G	IL62-M10S	1000	M10x1.50	1/2	3/4	1 1/4	2-3/4	2	3/16
IL62-M12G	IL62-M12S	2000	M12x1.75	1/2	3/4	1 1/4	2-3/4	2	3/16
IL62-M16G	IL62-M16S	3000	M16x2.00	5/8	3/4	1 1/4	2-3/4	2	3/16
IL62-M20G	IL62-M20S	4000	M20x2.50	3/4	3/4	1 1/4	2-3/4	2	3/16
IL62-M24G	IL62-M24S	5000	M24x3.00	1	1	1 1/4	3	2	1/2
IL64-M6G	IL64-M6S	100	M6x1	1/2	3/4	1 7/8	2-3/4	2	3/16
IL64-M8G	IL64-M8S	500	M8x1.25	1/2	3/4	1 7/8	2-3/4	2	3/16
IL64-M10G	IL64-M10S	3000	M10x1.50	1/2	3/4	1 7/8	2-3/4	2	3/16
IL64-M12G	IL64-M12S	5000	M12x1.75	1/2	3/4	1 7/8	2-3/4	2	3/16
IL64-M16G	IL64-M16S	6000	M16x2.00	5/8	3/4	1 7/8	2-3/4	2	3/16
IL64-M20G	IL64-M20S	8000	M20x2.50	3/4	3/4	1 7/8	2-3/4	2	3/16
IL64-M24G	IL64-M24S	10000	M24x3.00	1	1	1 7/8	3	2	1/2
IL66-M6G	IL66-M6S	100	M6x1	1/2	3/4	2 1/2	2-3/4	2	3/16
IL66-M8G	IL66-M8S	500	M8x1.25	1/2	3/4	2 1/2	2-3/4	2	3/16
IL66-M10G	IL66-M10S	3000	M10x1.50	1/2	3/4	2 1/2	2-3/4	2	3/16
IL66-M12G	IL66-M12S	5000	M12x1.75	1/2	3/4	2 1/2	2-3/4	2	3/16
IL66-M16G	IL66-M16S	6000	M16x2.00	5/8	3/4	2 1/2	2-3/4	2	3/16
IL66-M20G	IL66-M20S	8000	M20x2.50	3/4	3/4	2 1/2	2-3/4	2	3/16
IL66-M24G	IL66-M24S	10000	M24x3.00	1	1	2 1/2	3	2	1/2
IL68-M6G	IL68-M6S	100	M6x1	1/2	3/4	3	2-3/4	2	3/16
IL68-M8G	IL68-M8S	500	M8x1.25	1/2	3/4	3	2-3/4	2	3/16
IL68-M10G	IL68-M10S	3000	M10x1.50	1/2	3/4	3	2-3/4	2	3/16
IL68-M12G	IL68-M12S	5000	M12x1.75	1/2	3/4	3	2-3/4	2	3/16
IL68-M16G	IL68-M16S	6000	M16x2.00	5/8	3/4	3	2-3/4	2	3/16
IL68-M20G	IL68-M20S	8000	M20x2.50	3/4	3/4	3	2-3/4	2	3/16
IL68-M24G	IL68-M24S	10000	M24x3.00	1	1	3	3	2	1/2
IL70-M6G	IL70-M6S	100	M6x1	1/2	3/4	4	2-3/4	2	3/16
IL70-M8G	IL70-M8S	500	M8x1.25	1/2	3/4	4	2-3/4	2	3/16
IL70-M10G	IL70-M10S	3000	M10x1.50	1/2	3/4	4	2-3/4	2	3/16
IL70-M12G	IL70-M12S	5000	M12x1.75	1/2	3/4	4	2-3/4	2	3/16
IL70-M16G	IL70-M16S	6000	M16x2.00	5/8	3/4	4	2-3/4	2	3/16
IL70-M20G	IL70-M20S	8000	M20x2.50	3/4	3/4	4	2-3/4	2	3/16
IL70-M24G	IL70-M24S	10000	M24x3.00	1	1	4	3	2	1/2

To order with 1/8" black rubber pad, (add "-P"). To order optional top broached hex, "allen drive," add "-BR". To order with two (2) 5/8" dia. lag holes centered at 2-3/4", (add "-H"). Only available on 4" base.

Top Hex (Allen-drive) Thread & Hex Size							
Thread	M6x1	M8x1.25	M10x1.50	M12x1.75	M16x2.00	M20x2.50	M24x3.00
Hex Size	3mm	4mm	5mm	6mm	8mm	10mm	12mm



LOW-PROFILE METRIC STUD LEVELERS

The IEC *Metric Low-Profile Stud Leveler* features an exclusive ball design that minimizes base separation. Ideal for heavy-duty load requirements. Integrated ball and swivel socket provide a low-friction support interface. Perfect for cabinets, instruments, machinery and equipment.

Features

- Steel/stainless steel options
- Integrated ball and stud
- Adjustable height
- Base adjusts 15° off centerline
- Standard gold irridite zinc finish
- Black oxide or clear chromate options
- Optional rubber pad (add -P)
- Non-tilt and extended stud length designs (2" - 8")
- Optional Top-A-Just™ shown at right. (add "-BR" to P/N)

Applications

- Electronic equipment
- Enclosures
- Conveyors
- Machinery
- Work tables
- Display racks

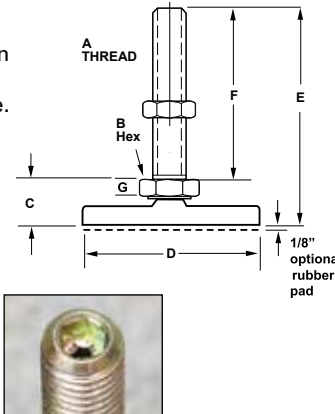

LOW PROFILE - METRIC STEEL & STAINLESS STEEL (3" STUD)

Steel	Stainless	Load	A	B	C	D	E	F	G
IL60-M8Gx3	IL60-M8Sx3	500	M8x1.25	1/2	3/4	3/4	3-3/4	3	3/16
IL60-M10Gx3	IL60-M10Sx3	1000	M10x1.50	1/2	3/4	3/4	3-3/4	3	3/16
IL60-M12Gx3	IL60-M12Sx3	2000	M12x1.75	1/2	3/4	3/4	3-3/4	3	3/16
IL60-M16Gx3	IL60-M16Sx3	3000	M16x2.00	5/8	3/4	3/4	3-3/4	3	3/16
IL60-M20Gx3	IL60-M20Sx3	4000	M20x2.50	3/4	3/4	3/4	3-3/4	3	1/2
IL60-M24Gx3	IL60-M24Sx3	5000	M24x3.00	1	1	3/4	4	3	1/2
IL62-M8Gx3	IL62-M8Sx3	500	M8x1.25	1/2	3/4	1 1/4	3-3/4	3	3/16
IL62-M10Gx3	IL62-M10Sx3	1000	M10x1.50	1/2	3/4	1 1/4	3-3/4	3	3/16
IL62-M12Gx3	IL62-M12Sx3	2000	M12x1.75	1/2	3/4	1 1/4	3-3/4	3	3/16
IL62-M16Gx3	IL62-M16Sx3	3000	M16x2.00	5/8	3/4	1 1/4	3-3/4	3	3/16
IL62-M20Gx3	IL62-M20Sx3	4000	M20x2.50	3/4	3/4	1 1/4	3-3/4	3	1/2
IL62-M24Gx3	IL62-M24Sx3	5000	M24x3.00	1	1	1 1/4	4	3	1/2
IL64-M8Gx3	IL64-M8Sx3	500	M8x1.25	1/2	3/4	1 7/8	3-3/4	3	3/16
IL64-M10Gx3	IL64-M10Sx3	3000	M10x1.50	1/2	3/4	1 7/8	3-3/4	3	3/16
IL64-M12Gx3	IL64-M12Sx3	5000	M12x1.75	1/2	3/4	1 7/8	3-3/4	3	3/16
IL64-M16Gx3	IL64-M16Sx3	6000	M16x2.00	5/8	3/4	1 7/8	3-3/4	3	3/16
IL64-M20Gx3	IL64-M20Sx3	8000	M20x2.50	3/4	3/4	1 7/8	3-3/4	3	1/2
IL64-M24Gx3	IL64-M24Sx3	10000	M24x3.00	1	1	1 7/8	4	3	1/2
IL66-M8Gx3	IL66-M8Sx3	500	M8x1.25	1/2	3/4	2 1/2	3-3/4	3	3/16
IL66-M10Gx3	IL66-M10Sx3	3000	M10x1.50	1/2	3/4	2 1/2	3-3/4	3	3/16
IL66-M12Gx3	IL66-M12Sx3	5000	M12x1.75	1/2	3/4	2 1/2	3-3/4	3	3/16
IL66-M16Gx3	IL66-M16Sx3	6000	M16x2.00	5/8	3/4	2 1/2	3-3/4	3	3/16
IL66-M20Gx3	IL66-M20Sx3	8000	M20x2.50	3/4	3/4	2 1/2	3-3/4	3	1/2
IL66-M24Gx3	IL66-M24Sx3	10000	M24x3.00	1	1	2 1/2	4	3	1/2
IL68-M8Gx3	IL68-M8Sx3	500	M8x1.25	1/2	3/4	3	3-3/4	3	3/16
IL68-M10Gx3	IL68-M10Sx3	3000	M10x1.50	1/2	3/4	3	3-3/4	3	3/16
IL68-M12Gx3	IL68-M12Sx3	5000	M12x1.75	1/2	3/4	3	3-3/4	3	3/16
IL68-M16Gx3	IL68-M16Sx3	6000	M16x2.00	5/8	3/4	3	3-3/4	3	3/16
IL68-M20Gx3	IL68-M20Sx3	8000	M20x2.50	3/4	3/4	3	3-3/4	3	1/2
IL68-M24Gx3	IL68-M24Sx3	10000	M24x3.00	1	1	3	4	3	1/2
IL70-M8Gx3	IL70-M8Sx3	500	M8x1.25	1/2	3/4	4	3-3/4	3	3/16
IL70-M10Gx3	IL70-M10Sx3	3000	M10x1.50	1/2	3/4	4	3-3/4	3	3/16
IL70-M12Gx3	IL70-M12Sx3	5000	M12x1.75	1/2	3/4	4	3-3/4	3	3/16
IL70-M16Gx3	IL70-M16Sx3	6000	M16x2.00	5/8	3/4	4	3-3/4	3	3/16
IL70-M20Gx3	IL70-M20Sx3	8000	M20x2.50	3/4	3/4	4	3-3/4	3	1/2
IL70-M24Gx3	IL70-M24Sx3	10000	M24x3.00	1	1	4	4	3	1/2

To order with 1/8" black rubber pad, (add "-P"). To order optional top broached hex, "allen drive," add "-BR". To order with two (2) 5/8" dia. lag holes centered at 2-3/4", (add "-H"). Only available on 4" base.

Top Hex (Allen-drive) Thread & Hex Size							
Thread	M6x1	M8x1.25	M10x1.50	M12x1.75	M16x2.00	M20x2.50	M24x3.00
Hex Size	3mm	4mm	5mm	6mm	8mm	10mm	12mm



LOW-PROFILE METRIC STUD LEVELERS

The IEC *Metric Low-Profile Stud Leveler* features an exclusive ball design that minimizes base separation. Ideal for heavy-duty load requirements. Integrated ball and swivel socket provide a low-friction support interface. Perfect for cabinets, instruments, machinery and equipment.

Features

- Steel/stainless steel options
- Integrated ball and stud
- Adjustable height
- Base adjusts 15° off centerline
- Standard gold irridite zinc finish
- Black oxide or clear chromate options
- Optional rubber pad (add -P)
- Non-tilt and extended stud length designs (2" - 8")
- Optional Top-A-Just™ shown at right. (add "-BR" to P/N)

Applications

- Electronic equipment
- Enclosures
- Conveyors
- Machinery
- Work tables
- Display racks

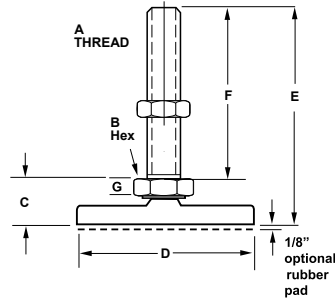

LOW PROFILE - METRIC STEEL & STAINLESS STEEL (4" STUD)

Steel	Stainless	Load	A	B	C	D	E	F	G
IL60-M8Gx4	IL60-M8Sx4	500	M8x1.25	1/2	3/4	3/4	4-3/4	4	3/16
IL60-M10Gx4	IL60-M10Sx4	1000	M10x1.50	1/2	3/4	3/4	4-3/4	4	3/16
IL60-M12Gx4	IL60-M12Sx4	2000	M12x1.75	1/2	3/4	3/4	4-3/4	4	3/16
IL60-M16Gx4	IL60-M16Sx4	3000	M16x2.00	5/8	3/4	3/4	4-3/4	4	3/16
IL60-M20Gx4	IL60-M20Sx4	4000	M20x2.50	3/4	3/4	3/4	4-3/4	4	1/2
IL60-M24Gx4	IL60-M24Sx4	5000	M24x3.00	1	1	3/4	5	4	1/2
IL62-M8Gx4	IL62-M8Sx4	500	M8x1.25	1/2	3/4	1 1/4	4-3/4	4	3/16
IL62-M10Gx4	IL62-M10Sx4	1000	M10x1.50	1/2	3/4	1 1/4	4-3/4	4	3/16
IL62-M12Gx4	IL62-M12Sx4	2000	M12x1.75	1/2	3/4	1 1/4	4-3/4	4	3/16
IL62-M16Gx4	IL62-M16Sx4	3000	M16x2.00	5/8	3/4	1 1/4	4-3/4	4	3/16
IL62-M20Gx4	IL62-M20Sx4	4000	M20x2.50	3/4	3/4	1 1/4	4-3/4	4	1/2
IL62-M24Gx4	IL62-M24Sx4	5000	M24x3.00	1	1	1 1/4	5	4	1/2
IL64-M8Gx4	IL64-M8Sx4	500	M8x1.25	1/2	3/4	1 7/8	4-3/4	4	3/16
IL64-M10Gx4	IL64-M10Sx4	3000	M10x1.50	1/2	3/4	1 7/8	4-3/4	4	3/16
IL64-M12Gx4	IL64-M12Sx4	5000	M12x1.75	1/2	3/4	1 7/8	4-3/4	4	3/16
IL64-M16Gx4	IL64-M16Sx4	6000	M16x2.00	5/8	3/4	1 7/8	4-3/4	4	3/16
IL64-M20Gx4	IL64-M20Sx4	8000	M20x2.50	3/4	3/4	1 7/8	4-3/4	4	1/2
IL64-M24Gx4	IL64-M24Sx4	10000	M24x3.00	1	1	1 7/8	5	4	1/2
IL66-M8Gx4	IL66-M8Sx4	500	M8x1.25	1/2	3/4	2 1/2	4-3/4	4	3/16
IL66-M10Gx4	IL66-M10Sx4	3000	M10x1.50	1/2	3/4	2 1/2	4-3/4	4	3/16
IL66-M12Gx4	IL66-M12Sx4	5000	M12x1.75	1/2	3/4	2 1/2	4-3/4	4	3/16
IL66-M16Gx4	IL66-M16Sx4	6000	M16x2.00	5/8	3/4	2 1/2	4-3/4	4	3/16
IL66-M20Gx4	IL66-M20Sx4	8000	M20x2.50	3/4	3/4	2 1/2	4-3/4	4	1/2
IL66-M24Gx4	IL66-M24Sx4	10000	M24x3.00	1	1	2 1/2	5	4	1/2
IL68-M8Gx4	IL68-M8Sx4	500	M8x1.25	1/2	3/4	3	4-3/4	4	3/16
IL68-M10Gx4	IL68-M10Sx4	3000	M10x1.50	1/2	3/4	3	4-3/4	4	3/16
IL68-M12Gx4	IL68-M12Sx4	5000	M12x1.75	1/2	3/4	3	4-3/4	4	3/16
IL68-M16Gx4	IL68-M16Sx4	6000	M16x2.00	5/8	3/4	3	4-3/4	4	3/16
IL68-M20Gx4	IL68-M20Sx4	8000	M20x2.50	3/4	3/4	3	4-3/4	4	1/2
IL68-M24Gx4	IL68-M24Sx4	10000	M24x3.00	1	1	3	5	4	1/2
IL70-M8Gx4	IL70-M8Sx4	500	M8x1.25	1/2	3/4	4	4-3/4	4	3/16
IL70-M10Gx4	IL70-M10Sx4	3000	M10x1.50	1/2	3/4	4	4-3/4	4	3/16
IL70-M12Gx4	IL70-M12Sx4	5000	M12x1.75	1/2	3/4	4	4-3/4	4	3/16
IL70-M16Gx4	IL70-M16Sx4	6000	M16x2.00	5/8	3/4	4	4-3/4	4	3/16
IL70-M20Gx4	IL70-M20Sx4	8000	M20x2.50	3/4	3/4	4	4-3/4	4	1/2
IL70-M24Gx4	IL70-M24Sx4	10000	M24x3.00	1	1	4	5	4	1/2

To order with 1/8" black rubber pad, (add "-P"). To order optional top broached hex, "allen drive," add "-BR". To order with two (2) 5/8" dia. lag holes centered at 2-3/4", (add "-H"). Only available on 4" base.

Top Hex (Allen-drive) Thread & Hex Size							
Thread	M6x1	M8x1.25	M10x1.50	M12x1.75	M16x2.00	M20x2.50	M24x3.00
Hex Size	3mm	4mm	5mm	6mm	8mm	10mm	12mm



LOW-PROFILE METRIC STUD LEVELERS

The IEC *Metric Low-Profile Stud Leveler* features an exclusive ball design that minimizes base separation. Ideal for heavy-duty load requirements. Integrated ball and swivel socket provide a low-friction support interface. Perfect for cabinets, instruments, machinery and equipment.

Features

- Steel/stainless steel options
- Integrated ball and stud
- Adjustable height
- Base adjusts 15° off centerline
- Standard gold irridite zinc finish
- Black oxide or clear chromate options
- Optional rubber pad (add -P)
- Non-tilt and extended stud length designs (2" - 8")
- Optional Top-A-Just™ shown at right. (add "-BR" to P/N)

Applications

- Electronic equipment
- Enclosures
- Conveyors
- Machinery
- Work tables
- Display racks

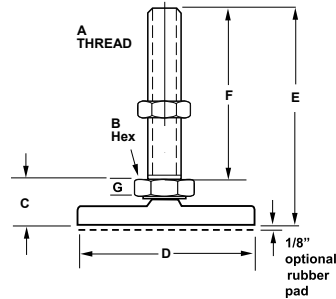

LOW PROFILE - METRIC STEEL & STAINLESS STEEL (5" STUD)

Steel	Stainless	Load	A	B	C	D	E	F	G
IL60-M10Gx5	IL60-M10Sx5	1000	M10x1.50	1/2	3/4	3/4	5-3/4	5	3/16
IL60-M12Gx5	IL60-M12Sx5	2000	M12x1.75	1/2	3/4	3/4	5-3/4	5	3/16
IL60-M16Gx5	IL60-M16Sx5	3000	M16x2.00	5/8	3/4	3/4	5-3/4	5	3/16
IL60-M20Gx5	IL60-M20Sx5	4000	M20x2.50	3/4	3/4	3/4	5-3/4	5	1/2
IL60-M24Gx5	IL60-M24Sx5	5000	M24x3.00	1	1	3/4	6	5	1/2
IL62-M10Gx5	IL62-M10Sx5	1000	M10x1.50	1/2	3/4	1 1/4	5-3/4	5	3/16
IL62-M12Gx5	IL62-M12Sx5	2000	M12x1.75	1/2	3/4	1 1/4	5-3/4	5	3/16
IL62-M16Gx5	IL62-M16Sx5	3000	M16x2.00	5/8	3/4	1 1/4	5-3/4	5	3/16
IL62-M20Gx5	IL62-M20Sx5	4000	M20x2.50	3/4	3/4	1 1/4	5-3/4	5	1/2
IL62-M24Gx5	IL62-M24Sx5	5000	M24x3.00	1	1	1 1/4	6	5	1/2
IL64-M10Gx5	IL64-M10Sx5	3000	M10x1.50	1/2	3/4	1 7/8	5-3/4	5	3/16
IL64-M12Gx5	IL64-M12Sx5	5000	M12x1.75	1/2	3/4	1 7/8	5-3/4	5	3/16
IL64-M16Gx5	IL64-M16Sx5	6000	M16x2.00	5/8	3/4	1 7/8	5-3/4	5	3/16
IL64-M20Gx5	IL64-M20Sx5	8000	M20x2.50	3/4	3/4	1 7/8	5-3/4	5	1/2
IL64-M24Gx5	IL64-M24Sx5	10000	M24x3.00	1	1	1 7/8	6	5	1/2
IL66-M10Gx5	IL66-M10Sx5	3000	M10x1.50	1/2	3/4	2 1/2	5-3/4	5	3/16
IL66-M12Gx5	IL66-M12Sx5	5000	M12x1.75	1/2	3/4	2 1/2	5-3/4	5	3/16
IL66-M16Gx5	IL66-M16Sx5	6000	M16x2.00	5/8	3/4	2 1/2	5-3/4	5	3/16
IL66-M20Gx5	IL66-M20Sx5	8000	M20x2.50	3/4	3/4	2 1/2	5-3/4	5	1/2
IL66-M24Gx5	IL66-M24Sx5	10000	M24x3.00	1	1	2 1/2	6	5	1/2
IL68-M10Gx5	IL68-M10Sx5	3000	M10x1.50	1/2	3/4	3	5-3/4	5	3/16
IL68-M12Gx5	IL68-M12Sx5	5000	M12x1.75	1/2	3/4	3	5-3/4	5	3/16
IL68-M16Gx5	IL68-M16Sx5	6000	M16x2.00	5/8	3/4	3	5-3/4	5	3/16
IL68-M20Gx5	IL68-M20Sx5	8000	M20x2.50	3/4	3/4	3	5-3/4	5	1/2
IL68-M24Gx5	IL68-M24Sx5	10000	M24x3.00	1	1	3	6	5	1/2
IL70-M10Gx5	IL70-M10Sx5	3000	M10x1.50	1/2	3/4	4	5-3/4	5	3/16
IL70-M12Gx5	IL70-M12Sx5	5000	M12x1.75	1/2	3/4	4	5-3/4	5	3/16
IL70-M16Gx5	IL70-M16Sx5	6000	M16x2.00	5/8	3/4	4	5-3/4	5	3/16
IL70-M20Gx5	IL70-M20Sx5	8000	M20x2.50	3/4	3/4	4	5-3/4	5	1/2
IL70-M24Gx5	IL70-M24Sx5	10000	M24x3.00	1	1	4	6	5	1/2

To order with 1/8" black rubber pad, (add "-P"). To order optional top broached hex, "allen drive," add "-BR". To order with two (2) 5/8" dia. lag holes centered at 2-3/4", (add "-H"). Only available on 4" base.

Top Hex (Allen-drive) Thread & Hex Size							
Thread	M6x1	M8x1.25	M10x1.50	M12x1.75	M16x2.00	M20x2.50	M24x3.00
Hex Size	3mm	4mm	5mm	6mm	8mm	10mm	12mm



LOW-PROFILE METRIC STUD LEVELERS

The IEC *Metric Low-Profile Stud Leveler* features an exclusive ball design that minimizes base separation. Ideal for heavy-duty load requirements. Integrated ball and swivel socket provide a low-friction support interface. Perfect for cabinets, instruments, machinery and equipment.

Features

- Steel/stainless steel options
- Integrated ball and stud
- Adjustable height
- Base adjusts 15° off centerline
- Standard gold irridite zinc finish
- Black oxide or clear chromate options
- Optional rubber pad (add -P)
- Non-tilt and extended stud length designs (2" - 8")
- Optional Top-A-Just™ shown at right. (add "-BR" to P/N)

Applications

- Electronic equipment
- Enclosures
- Conveyors
- Machinery
- Work tables
- Display racks

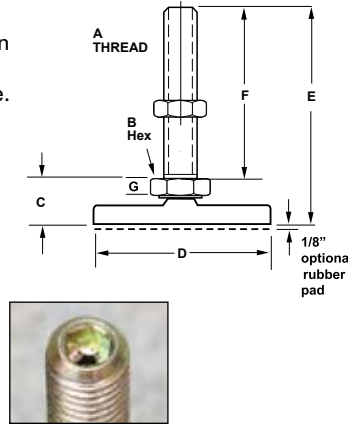

LOW PROFILE - METRIC STEEL & STAINLESS STEEL (6" STUD)

Steel	Stainless	Load	A	B	C	D	E	F	G
IL60-M10Gx6	IL60-M10Sx6	1000	M10x1.50	1/2	3/4	3/4	6-3/4	6	3/16
IL60-M12Gx6	IL60-M12Sx6	2000	M12x1.75	1/2	3/4	3/4	6-3/4	6	3/16
IL60-M16Gx6	IL60-M16Sx6	3000	M16x2.00	5/8	3/4	3/4	6-3/4	6	3/16
IL60-M20Gx6	IL60-M20Sx6	4000	M20x2.50	3/4	3/4	3/4	6-3/4	6	1/2
IL60-M24Gx6	IL60-M24Sx6	5000	M24x3.00	1	1	3/4	7	6	1/2
IL62-M10Gx6	IL62-M10Sx6	1000	M10x1.50	1/2	3/4	1 1/4	6-3/4	6	3/16
IL62-M12Gx6	IL62-M12Sx6	2000	M12x1.75	1/2	3/4	1 1/4	6-3/4	6	3/16
IL62-M16Gx6	IL62-M16Sx6	3000	M16x2.00	5/8	3/4	1 1/4	6-3/4	6	3/16
IL62-M20Gx6	IL62-M20Sx6	4000	M20x2.50	3/4	3/4	1 1/4	6-3/4	6	1/2
IL62-M24Gx6	IL62-M24Sx6	5000	M24x3.00	1	1	1 1/4	7	6	1/2
IL64-M10Gx6	IL64-M10Sx6	3000	M10x1.50	1/2	3/4	1 7/8	6-3/4	6	3/16
IL64-M12Gx6	IL64-M12Sx6	5000	M12x1.75	1/2	3/4	1 7/8	6-3/4	6	3/16
IL64-M16Gx6	IL64-M16Sx6	6000	M16x2.00	5/8	3/4	1 7/8	6-3/4	6	3/16
IL64-M20Gx6	IL64-M20Sx6	8000	M20x2.50	3/4	3/4	1 7/8	6-3/4	6	1/2
IL64-M24Gx6	IL64-M24Sx6	10000	M24x3.00	1	1	1 7/8	7	6	1/2
IL66-M10Gx6	IL66-M10Sx6	3000	M10x1.50	1/2	3/4	2 1/2	6-3/4	6	3/16
IL66-M12Gx6	IL66-M12Sx6	5000	M12x1.75	1/2	3/4	2 1/2	6-3/4	6	3/16
IL66-M16Gx6	IL66-M16Sx6	6000	M16x2.00	5/8	3/4	2 1/2	6-3/4	6	3/16
IL66-M20Gx6	IL66-M20Sx6	8000	M20x2.50	3/4	3/4	2 1/2	6-3/4	6	1/2
IL66-M24Gx6	IL66-M24Sx6	10000	M24x3.00	1	1	2 1/2	7	6	1/2
IL68-M10Gx6	IL68-M10Sx6	3000	M10x1.50	1/2	3/4	3	6-3/4	6	3/16
IL68-M12Gx6	IL68-M12Sx6	5000	M12x1.75	1/2	3/4	3	6-3/4	6	3/16
IL68-M16Gx6	IL68-M16Sx6	6000	M16x2.00	5/8	3/4	3	6-3/4	6	3/16
IL68-M20Gx6	IL68-M20Sx6	8000	M20x2.50	3/4	3/4	3	6-3/4	6	1/2
IL68-M24Gx6	IL68-M24Sx6	1000	M24x3.00	1	1	3	7	6	1/2
IL70-M10Gx6	IL70-M10Sx6	3000	M10x1.50	1/2	3/4	4	6-3/4	6	3/16
IL70-M12Gx6	IL70-M12Sx6	5000	M12x1.75	1/2	3/4	4	6-3/4	6	3/16
IL70-M16Gx6	IL70-M16Sx6	6000	M16x2.00	5/8	3/4	4	6-3/4	6	3/16
IL70-M20Gx6	IL70-M20Sx6	8000	M20x2.50	3/4	3/4	4	6-3/4	6	1/2
IL70-M24Gx6	IL70-M24Sx6	10000	M24x3.00	1	1	4	7	6	1/2

To order with 1/8" black rubber pad, (add "-P"). To order optional top broached hex, "allen drive," add "-BR". To order with two (2) 5/8" dia. lag holes centered at 2-3/4", (add "-H"). Only available on 4" base.

Top Hex (Allen-drive) Thread & Hex Size							
Thread	M6x1	M8x1.25	M10x1.50	M12x1.75	M16x2.00	M20x2.50	M24x3.00
Hex Size	3mm	4mm	5mm	6mm	8mm	10mm	12mm



LOW-PROFILE METRIC STUD LEVELERS

The IEC *Metric Low-Profile Stud Leveler* features an exclusive ball design that minimizes base separation. Ideal for heavy-duty load requirements. Integrated ball and swivel socket provide a low-friction support interface. Perfect for cabinets, instruments, machinery and equipment.

Features

- Steel/stainless steel options
- Integrated ball and stud
- Adjustable height
- Base adjusts 15° off centerline
- Standard gold irridite zinc finish
- Black oxide or clear chromate options
- Optional rubber pad (add -P)
- Non-tilt and extended stud length designs (2" - 8")
- Optional Top-A-Just™ shown at right. (add "-BR" to P/N)

Applications

- Electronic equipment
- Enclosures
- Conveyors
- Machinery
- Work tables
- Display racks

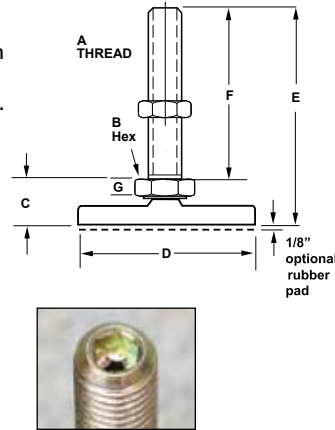

LOW PROFILE - METRIC STEEL & STAINLESS STEEL (8" STUD)

Steel	Stainless	Load	A	B	C	D	E	F	G
IL60-M12Gx8	IL60-M12Sx8	2000	M12x1.75	1/2	3/4	3/4	8-3/4	8	3/16
IL60-M16Gx8	IL60-M16Sx8	3000	M16x2.00	5/8	3/4	3/4	8-3/4	8	3/16
IL60-M20Gx8	IL60-M20Sx8	4000	M20x2.50	3/4	3/4	3/4	8-3/4	8	3/16
IL60-M24Gx8	IL60-M24Sx8	5000	M24x3.00	1	1	3/4	9	8	1/2
IL62-M12Gx8	IL62-M12Sx8	2000	M12x1.75	1/2	3/4	1 1/4	8-3/4	8	3/16
IL62-M16Gx8	IL62-M16Sx8	3000	M16x2.00	5/8	3/4	1 1/4	8-3/4	8	3/16
IL62-M20Gx8	IL62-M20Sx8	4000	M20x2.50	3/4	3/4	1 1/4	8-3/4	8	3/16
IL62-M24Gx8	IL62-M24Sx8	5000	M24x3.00	1	1	1 1/4	9	8	1/2
IL64-M12Gx8	IL64-M12Sx8	5000	M12x1.75	1/2	3/4	1 7/8	8-3/4	8	3/16
IL64-M16Gx8	IL64-M16Sx8	6000	M16x2.00	5/8	3/4	1 7/8	8-3/4	8	3/16
IL64-M20Gx8	IL64-M20Sx8	8000	M20x2.50	3/4	3/4	1 7/8	8-3/4	8	3/16
IL64-M24Gx8	IL64-M24Sx8	10000	M24x3.00	1	1	1 7/8	9	8	1/2
IL66-M12Gx8	IL66-M12Sx8	5000	M12x1.75	1/2	3/4	2 1/2	8-3/4	8	3/16
IL66-M16Gx8	IL66-M16Sx8	6000	M16x2.00	5/8	3/4	2 1/2	8-3/4	8	3/16
IL66-M20Gx8	IL66-M20Sx8	8000	M20x2.50	3/4	3/4	2 1/2	8-3/4	8	3/16
IL66-M24Gx8	IL66-M24Sx8	10000	M24x3.00	1	1	2 1/2	9	8	1/2
IL68-M12Gx8	IL68-M12Sx8	5000	M12x1.75	1/2	3/4	3	8-3/4	8	3/16
IL68-M16Gx8	IL68-M16Sx8	6000	M16x2.00	5/8	3/4	3	8-3/4	8	3/16
IL68-M20Gx8	IL68-M20Sx8	8000	M20x2.50	3/4	3/4	3	8-3/4	8	3/16
IL68-M24Gx8	IL68-M24Sx8	10000	M24x3.00	1	1	3	9	8	1/2
IL70-M12Gx8	IL70-M12Sx8	5000	M12x1.75	1/2	3/4	4	8-3/4	8	3/16
IL70-M16Gx8	IL70-M16Sx8	6000	M16x2.00	5/8	3/4	4	8-3/4	8	3/16
IL70-M20Gx8	IL70-M20Sx8	8000	M20x2.50	3/4	3/4	4	8-3/4	8	3/16
IL70-M24Gx8	IL70-M24Sx8	10000	M24x3.00	1	1	4	9	8	1/2

To order with 1/8" black rubber pad, (add "-P"). To order optional top broached hex, "allen drive," add "-BR".
 To order with two (2) 5/8" dia. lag holes centered at 2-3/4", (add "-H"). Only available on 4" base.

Top Hex (Allen-drive) Thread & Hex Size							
Thread	M6x1	M8x1.25	M10x1.50	M12x1.75	M16x2.00	M20x2.50	M24x3.00
Hex Size	3mm	4mm	5mm	6mm	8mm	10mm	12mm



TOGGLE PADS - SOCKET

The IEC *Socket Toggle Pad* features an exclusive ball design that minimizes base separation. Ideal for heavy-duty load requirements. The threaded female socket allows use of your own stud or bolt. Integrated ball and swivel socket provide a low-friction support interface. Standard steel finish is corrosion resistant zinc-plated gold irridite. Other finishes available upon request.

Features

- Steel/stainless steel options
- Integrated ball and socket
- White Delrin (nylon) base option
- Black delrin available as custom item (change to -BD)

Applications

- Electronic equipment
- Enclosures
- Conveyors
- Fixtures / Tooling

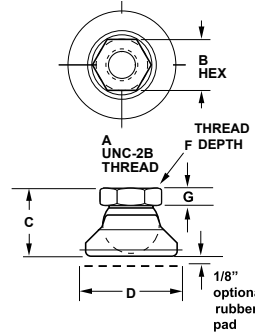

TOGGLE PADS - STEEL & STAINLESS STEEL SOCKET

Steel	Stainless	Load	A	B	C	D	F	G
IL61-4G	IL61-4S	100	1/4-20	1/2	5/8	3/4	3/8	3/16
IL61-5G	IL61-5S	500	5/16-18	1/2	5/8	3/4	3/8	3/16
IL61-6G	IL61-6S	1000	3/8-16	1/2	5/8	3/4	3/8	3/16
IL61-7G	IL61-7S	2000	1/2-13	1/2	15/16	3/4	3/8	1/2
IL61-8G	IL61-8S	3000	5/8-11	5/8	1-1/8	3/4	1/2	5/8
IL61-9G	IL61-9S	4000	3/4-10	3/4	1-3/16	3/4	5/8	11/16
IL61-10G	IL61-10S	5000	1-8	1	1-1/4	3/4	11/16	3/4
IL63-4G	IL63-4S	100	1/4-20	1/2	5/8	1-1/4	3/8	3/16
IL63-5G	IL63-5S	500	5/16-18	1/2	5/8	1-1/4	3/8	3/16
IL63-6G	IL63-6S	1000	3/8-16	1/2	5/8	1-1/4	3/8	3/16
IL63-7G	IL63-7S	2000	1/2-13	1/2	15/16	1-1/4	3/8	1/2
IL63-8G	IL63-8S	3000	5/8-11	5/8	1-1/8	1-1/4	1/2	5/8
IL63-9G	IL63-9S	4000	3/4-10	3/4	1-3/16	1-1/4	5/8	11/16
IL63-10G	IL63-10S	5000	1-8	1	1-1/4	1-1/4	11/16	3/4

To order with 1/8" black rubber pad, (add "-P").

TOGGLE PADS (Delrin Base) - STEEL/STAINLESS STEEL SOCKET

Steel	Stainless	Load	A	B	C	D	F	G
IL61-4G-WD	IL61-4S-WD	100	1/4-20	1/2	5/8	3/4	3/8	3/16
IL61-5G-WD	IL61-5S-WD	300	5/16-18	1/2	5/8	3/4	3/8	3/16
IL61-6G-WD	IL61-6S-WD	500	3/8-16	1/2	5/8	3/4	3/8	3/16
IL61-7G-WD	IL61-7S-WD	750	1/2-13	1/2	15/16	3/4	3/8	1/2
IL61-8G-WD	IL61-8S-WD	1000	5/8-11	5/8	1-1/8	3/4	1/2	5/8
IL61-9G-WD	IL61-9S-WD	1250	3/4-10	3/4	1-3/16	3/4	5/8	11/16
IL61-10G-WD	IL61-10S-WD	1500	1-8	1	1-1/4	3/4	11/16	3/4
IL63-4G-WD	IL63-4S-WD	100	1/4-20	1/2	5/8	1-1/4	3/8	3/16
IL63-5G-WD	IL63-5S-WD	300	5/16-18	1/2	5/8	1-1/4	3/8	3/16
IL63-6G-WD	IL63-6S-WD	500	3/8-16	1/2	5/8	1-1/4	3/8	3/16
IL63-7G-WD	IL63-7S-WD	750	1/2-13	1/2	15/16	1-1/4	3/8	1/2
IL63-8G-WD	IL63-8S-WD	1000	5/8-11	5/8	1-1/8	1-1/4	1/2	5/8
IL63-9G-WD	IL63-9S-WD	1250	3/4-10	3/4	1-3/16	1-1/4	5/8	11/16
IL63-10G-WD	IL63-10S-WD	1500	1-8	1	1-1/4	1-1/4	11/16	3/4





TOGGLE PADS - METRIC SOCKET

The IEC *Metric Socket Toggle Pad* features an exclusive ball design that minimizes base separation. Ideal for heavy-duty load requirements. The threaded female socket allows use of your own stud or bolt. Integrated ball and swivel socket provide a low-friction support interface. Standard steel finish is corrosion resistant zinc-plated gold irridite. Other finishes available upon request.

Features

- Steel/stainless steel options
- Integrated ball and socket
- White Delrin (nylon) base option
- Black delrin available as custom item (change to -BD)

Applications

- Electronic equipment
- Enclosures
- Conveyors
- Fixtures / Tooling

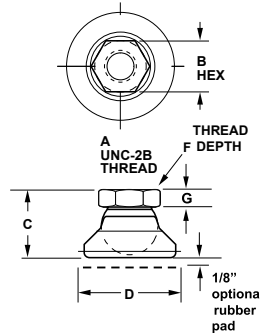

METRIC TOGGLE PADS - STEEL & STAINLESS STEEL SOCKET

Steel	Stainless	Load	A	B	C	D	F	G
IL61-M6G	IL61-M6S	100	M6x1	1/2	5/8	3/4	3/8	3/16
IL61-M8G	IL61-M8S	500	M8x1.25	1/2	5/8	3/4	3/8	3/16
IL61-M10G	IL61-M10S	1000	M10x1.50	1/2	5/8	3/4	3/8	3/16
IL61-M12G	IL61-M12S	2000	M12x1.75	1/2	15/16	3/4	3/8	1/2
IL61-M16G	IL61-M16S	3000	M16x2.00	5/8	1-1/8	3/4	1/2	5/8
IL61-M20G	IL61-M20S	4000	M20x2.50	3/4	1-3/16	3/4	5/8	11/16
IL61-M24G	IL61-M24S	5000	M24x3.00	1	1-1/4	3/4	11/16	3/4
IL63-M6G	IL63-M6S	100	M6x1	1/2	5/8	1 1/4	3/8	3/16
IL63-M8G	IL63-M8S	500	M8x1.25	1/2	5/8	1 1/4	3/8	3/16
IL63-M10G	IL63-M10S	1000	M10x1.50	1/2	5/8	1 1/4	3/8	3/16
IL63-M12G	IL63-M12S	2000	M12x1.75	1/2	15/16	1 1/4	3/8	1/2
IL63-M16G	IL63-M16S	3000	M16x2.00	5/8	1-1/8	1 1/4	1/2	5/8
IL63-M20G	IL63-M20S	4000	M20x2.50	3/4	1-3/16	1 1/4	5/8	11/16
IL63-M24G	IL63-M24S	5000	M24x3.00	1	1-1/4	1 1/4	11/16	3/4

To order with 1/8" black rubber pad, (add "-P").

METRIC TOGGLE PADS (Delrin Base) - STEEL/STAINLESS STEEL SOCKET

Steel	Stainless	Load	A	B	C	D	F	G
IL61-M6G-WD	IL61-M6S-WD	100	M6x1	1/2	5/8	3/4	3/8	3/16
IL61-M8G-WD	IL61-M8S-WD	300	M8x1.25	1/2	5/8	3/4	3/8	3/16
IL61-M10G-WD	IL61-M10S-WD	500	M10x1.50	1/2	5/8	3/4	3/8	3/16
IL61-M12G-WD	IL61-M12S-WD	750	M12x1.75	1/2	15/16	3/4	3/8	1/2
IL61-M16G-WD	IL61-M16S-WD	1000	M16x2.00	5/8	1-1/8	3/4	1/2	5/8
IL61-M20G-WD	IL61-M20S-WD	1250	M20x2.50	3/4	1-3/16	3/4	5/8	11/16
IL61-M24G-WD	IL61-M24S-WD	1500	M24x3.00	1	1-1/4	3/4	11/16	3/4
IL63-M6G-WD	IL63-M6S-WD	100	M6x1	1/2	5/8	1 1/4	3/8	3/16
IL63-M8G-WD	IL63-M8S-WD	300	M8x1.25	1/2	5/8	1 1/4	3/8	3/16
IL63-M10G-WD	IL63-M10S-WD	500	M10x1.50	1/2	5/8	1 1/4	3/8	3/16
IL63-M12G-WD	IL63-M12S-WD	750	M12x1.75	1/2	15/16	1 1/4	3/8	1/2
IL63-M16G-WD	IL63-M16S-WD	1000	M16x2.00	5/8	1-1/8	1 1/4	1/2	5/8
IL63-M20G-WD	IL63-M20S-WD	1250	M20x2.50	3/4	1-3/16	1 1/4	5/8	11/16
IL63-M24G-WD	IL63-M24S-WD	1500	M24x3.00	1	1-1/4	1 1/4	11/16	3/4





TOGGLE PADS - STUD (SWIVEL SET SCREWS)

The IEC *Stud Toggle Pad* features an exclusive ball design that minimizes base separation. Ideal for heavy-duty load requirements. The threaded female socket allows use of your own stud or bolt. Integrated ball and swivel socket provide a low-friction support interface. Standard steel finish is corrosion resistant zinc-plated gold irridite. Other finishes available upon request.

Features

- Steel/stainless steel options
- Integrated ball and stud
- Adjustable height
- Base adjusts 15° off centerline
- Standard gold irridite zinc finish
- Black oxide or clear chromate options
- Optional rubber pad (add -P)
- Non-tilt and extended stud length designs (2" - 8")
- Optional Top-A-Just™ shown at right. (add "-BR" to P/N)

Applications

- Electronic equipment
- Enclosures
- Conveyors
- Machinery
- Fixtures
- Tooling

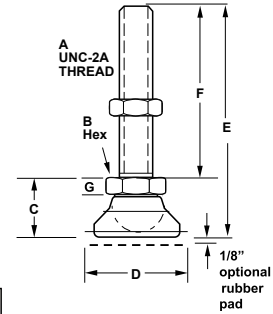

TOGGLE PADS - STEEL & STAINLESS STEEL STUD

Steel	Stainless	Load	A	B	C	D	E	F	G
IL60-4G	IL60-4S	100	1/4-20	1/2	3/4	3/4	2-3/4	2	3/16
IL60-5G	IL60-5S	500	5/16-18	1/2	3/4	3/4	2-3/4	2	3/16
IL60-6G	IL60-6S	1000	3/8-16	1/2	3/4	3/4	2-3/4	2	3/16
IL60-7G	IL60-7S	2000	1/2-13	1/2	3/4	3/4	2-3/4	2	3/16
IL60-8G	IL60-8S	3000	5/8-11	5/8	3/4	3/4	2-3/4	2	3/16
IL60-9G	IL60-9S	4000	3/4-10	3/4	3/4	3/4	2-3/4	2	3/16
IL60-10G	IL60-10S	5000	1-8	1	1	3/4	3	2	1/2
IL60-4Gx3	IL60-4Sx3	100	1/4-20	1/2	3/4	3/4	3-3/4	3	3/16
IL60-5Gx3	IL60-5Sx3	500	5/16-18	1/2	3/4	3/4	3-3/4	3	3/16
IL60-6Gx3	IL60-6Sx3	1000	3/8-16	1/2	3/4	3/4	3-3/4	3	3/16
IL60-7Gx3	IL60-7Sx3	2000	1/2-13	1/2	3/4	3/4	3-3/4	3	3/16
IL60-8Gx3	IL60-8Sx3	3000	5/8-11	5/8	3/4	3/4	3-3/4	3	3/16
IL60-9Gx3	IL60-9Sx3	4000	3/4-10	3/4	3/4	3/4	3-3/4	3	3/16
IL60-10Gx3	IL60-10Sx3	5000	1-8	1	1	3/4	4	3	1/2
IL60-5Gx4	IL60-5Sx4	500	5/16-18	1/2	3/4	3/4	4-3/4	4	3/16
IL60-6Gx4	IL60-6Sx4	1000	3/8-16	1/2	3/4	3/4	4-3/4	4	3/16
IL60-7Gx4	IL60-7Sx4	2000	1/2-13	1/2	3/4	3/4	4-3/4	4	3/16
IL60-8Gx4	IL60-8Sx4	3000	5/8-11	5/8	3/4	3/4	4-3/4	4	3/16
IL60-9Gx4	IL60-9Sx4	4000	3/4-10	3/4	3/4	3/4	4-3/4	4	3/16
IL60-10Gx4	IL60-10Sx4	5000	1-8	1	1	3/4	5	4	1/2
IL60-6Gx5	IL60-6Sx5	1000	3/8-16	1/2	3/4	3/4	5-3/4	5	3/16
IL60-7Gx5	IL60-7Sx5	2000	1/2-13	1/2	3/4	3/4	5-3/4	5	3/16
IL60-8Gx5	IL60-8Sx5	3000	5/8-11	5/8	3/4	3/4	5-3/4	5	3/16
IL60-9Gx5	IL60-9Sx5	4000	3/4-10	3/4	3/4	3/4	5-3/4	5	3/16
IL60-10Gx5	IL60-10Sx5	5000	1-8	1	1	3/4	6	5	1/2
IL60-6Gx6	IL60-6Sx6	1000	3/8-16	1/2	3/4	3/4	6-3/4	6	3/16
IL60-7Gx6	IL60-7Sx6	2000	1/2-13	1/2	3/4	3/4	6-3/4	6	3/16
IL60-8Gx6	IL60-8Sx6	3000	5/8-11	5/8	3/4	3/4	6-3/4	6	3/16
IL60-9Gx6	IL60-9Sx6	4000	3/4-10	3/4	3/4	3/4	6-3/4	6	3/16
IL60-10Gx6	IL60-10Sx6	5000	1-8	1	1	3/4	7	6	1/2
IL60-7Gx8	IL60-7Sx8	2000	1/2-13	1/2	3/4	3/4	8-3/4	8	3/16
IL60-8Gx8	IL60-8Sx8	3000	5/8-11	5/8	3/4	3/4	8-3/4	8	3/16
IL60-9Gx8	IL60-9Sx8	4000	3/4-10	3/4	3/4	3/4	8-3/4	8	3/16
IL60-10Gx8	IL60-10Sx8	5000	1-8	1	1	3/4	9	8	1/2



TOGGLE PADS - STUD (SWIVEL SET SCREWS)

The IEC *Stud Toggle Pad* features an exclusive ball design that minimizes base separation. Ideal for heavy-duty load requirements. The threaded female socket allows use of your own stud or bolt. Integrated ball and swivel socket provide a low-friction support interface. Standard steel finish is corrosion resistant zinc-plated gold irridite. Other finishes available upon request.

Features

- Steel/stainless steel options
- Integrated ball and stud
- Adjustable height
- Base adjusts 15° off centerline
- Standard gold irridite zinc finish
- Black oxide or clear chromate options
- Optional rubber pad (add -P)
- Non-tilt and extended stud length designs (2" - 8")
- Optional Top-A-Just™ shown at right. (add "-BR" to P/N)

Applications

- Electronic equipment
- Enclosures
- Conveyors
- Machinery
- Fixtures
- Tooling

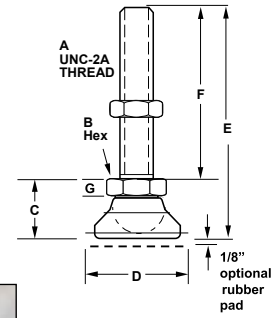

TOGGLE PADS - STEEL & STAINLESS STEEL STUD

Steel	Stainless	Load	A	B	C	D	E	F	G
IL62-4G	IL62-4S	100	1/4-20	1/2	3/4	1-1/4	2-3/4	2	3/16
IL62-5G	IL62-5S	500	5/16-18	1/2	3/4	1-1/4	2-3/4	2	3/16
IL62-6G	IL62-6S	1000	3/8-16	1/2	3/4	1-1/4	2-3/4	2	3/16
IL62-7G	IL62-7S	2000	1/2-13	1/2	3/4	1-1/4	2-3/4	2	3/16
IL62-8G	IL62-8S	3000	5/8-11	5/8	3/4	1-1/4	2-3/4	2	3/16
IL62-9G	IL62-9S	4000	3/4-10	3/4	3/4	1-1/4	2-3/4	2	3/16
IL62-10G	IL62-10S	5000	1-8	1	1	1-1/4	3	2	1/2
IL62-4Gx3	IL62-4Sx3	100	1/4-20	1/2	3/4	1-1/4	3-3/4	3	3/16
IL62-5Gx3	IL62-5Sx3	500	5/16-18	1/2	3/4	1-1/4	3-3/4	3	3/16
IL62-6Gx3	IL62-6Sx3	1000	3/8-16	1/2	3/4	1-1/4	3-3/4	3	3/16
IL62-7Gx3	IL62-7Sx3	2000	1/2-13	1/2	3/4	1-1/4	3-3/4	3	3/16
IL62-8Gx3	IL62-8Sx3	3000	5/8-11	5/8	3/4	1-1/4	3-3/4	3	3/16
IL62-9Gx3	IL62-9Sx3	4000	3/4-10	3/4	3/4	1-1/4	3-3/4	3	3/16
IL62-10Gx3	IL62-10Sx3	5000	1-8	1	1	1-1/4	4	3	1/2
IL62-5Gx4	IL62-5Sx4	500	5/16-18	1/2	3/4	1-1/4	4-3/4	4	3/16
IL62-6Gx4	IL62-6Sx4	1000	3/8-16	1/2	3/4	1-1/4	4-3/4	4	3/16
IL62-7Gx4	IL62-7Sx4	2000	1/2-13	1/2	3/4	1-1/4	4-3/4	4	3/16
IL62-8Gx4	IL62-8Sx4	3000	5/8-11	5/8	3/4	1-1/4	4-3/4	4	3/16
IL62-9Gx4	IL62-9Sx4	4000	3/4-10	3/4	3/4	1-1/4	4-3/4	4	3/16
IL62-10Gx4	IL62-10Sx4	5000	1-8	1	1	1-1/4	5	4	1/2
IL62-6Gx5	IL62-6Sx5	1000	3/8-16	1/2	3/4	1-1/4	5-3/4	5	3/16
IL62-7Gx5	IL62-7Sx5	2000	1/2-13	1/2	3/4	1-1/4	5-3/4	5	3/16
IL62-8Gx5	IL62-8Sx5	3000	5/8-11	5/8	3/4	1-1/4	5-3/4	5	3/16
IL62-9Gx5	IL62-9Sx5	4000	3/4-10	3/4	3/4	1-1/4	5-3/4	5	3/16
IL62-10Gx5	IL62-10Sx5	5000	1-8	1	1	1-1/4	6	5	1/2
IL62-6Gx6	IL62-6Sx6	1000	3/8-16	1/2	3/4	1-1/4	6-3/4	6	3/16
IL62-7Gx6	IL62-7Sx6	2000	1/2-13	1/2	3/4	1-1/4	6-3/4	6	3/16
IL62-8Gx6	IL62-8Sx6	3000	5/8-11	5/8	3/4	1-1/4	6-3/4	6	3/16
IL62-9Gx6	IL62-9Sx6	4000	3/4-10	3/4	3/4	1-1/4	6-3/4	6	3/16
IL62-10Gx6	IL62-10Sx6	5000	1-8	1	1	1-1/4	7	6	1/2
IL62-7Gx8	IL62-7Sx8	2000	1/2-13	1/2	3/4	1-1/4	8-3/4	8	3/16
IL62-8Gx8	IL62-8Sx8	3000	5/8-11	5/8	3/4	1-1/4	8-3/4	8	3/16
IL62-9Gx8	IL62-9Sx8	4000	3/4-10	3/4	3/4	1-1/4	8-3/4	8	3/16
IL62-10Gx8	IL62-10Sx8	5000	1-8	1	1	1-1/4	9	8	1/2



TOGGLE PADS - STUD (SWIVEL SET SCREWS)

The IEC *Delrin® Base Stud Toggle Pad* features an exclusive ball design that minimizes base separation. Ideal for heavy-duty load requirements. The threaded female socket allows use of your own stud or bolt. Integrated ball and swivel socket provide a low-friction support interface. Standard steel finish is corrosion resistant zinc-plated gold irridite. Other finishes available upon request.

Features

- Steel/stainless steel options
- Integrated ball and stud
- Adjustable height
- Base adjusts 15° off centerline
- Standard gold irridite zinc finish
- Black oxide or clear chromate options
- Black delrin available as custom
- Non-tilt and extended stud length designs (2" - 8")
- Optional Top-A-Just™ shown at right. (add "-BR" to P/N)

Applications

- Electronic equipment
- Enclosures
- Conveyors
- Machinery
- Fixtures
- Tooling

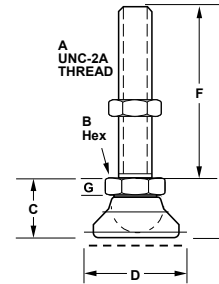

TOGGLE PADS (DELRIN BASE) - STEEL & STAINLESS STEEL STUD

Steel	Stainless	Load	A	B	C	D	E	F	G
IL60-4G-WD	IL60-4S-WD	100	1/4-20	1/2	3/4	3/4	2-3/4	2	3/16
IL60-5G-WD	IL60-5S-WD	300	5/16-18	1/2	3/4	3/4	2-3/4	2	3/16
IL60-6G-WD	IL60-6S-WD	500	3/8-16	1/2	3/4	3/4	2-3/4	2	3/16
IL60-7G-WD	IL60-7S-WD	750	1/2-13	1/2	3/4	3/4	2-3/4	2	3/16
IL60-8G-WD	IL60-8S-WD	1000	5/8-11	5/8	3/4	3/4	2-3/4	2	3/16
IL60-9G-WD	IL60-9S-WD	1250	3/4-10	3/4	3/4	3/4	2-3/4	2	3/16
IL60-10G-WD	IL60-10S-WD	1500	1-8	1	1	3/4	3	2	1/2
IL60-4Gx3-WD	IL60-4Sx3-WD	100	1/4-20	1/2	3/4	3/4	3-3/4	3	3/16
IL60-5Gx3-WD	IL60-5Sx3-WD	300	5/16-18	1/2	3/4	3/4	3-3/4	3	3/16
IL60-6Gx3-WD	IL60-6Sx3-WD	500	3/8-16	1/2	3/4	3/4	3-3/4	3	3/16
IL60-7Gx3-WD	IL60-7Sx3-WD	750	1/2-13	1/2	3/4	3/4	3-3/4	3	3/16
IL60-8Gx3-WD	IL60-8Sx3-WD	1000	5/8-11	5/8	3/4	3/4	3-3/4	3	3/16
IL60-9Gx3-WD	IL60-9Sx3-WD	1250	3/4-10	3/4	3/4	3/4	3-3/4	3	3/16
IL60-10Gx3-WD	IL60-10Sx3-WD	1500	1-8	1	1	3/4	4	3	1/2
IL60-5Gx4-WD	IL60-5Sx4-WD	300	5/16-18	1/2	3/4	3/4	4-3/4	4	3/16
IL60-6Gx4-WD	IL60-6Sx4-WD	500	3/8-16	1/2	3/4	3/4	4-3/4	4	3/16
IL60-7Gx4-WD	IL60-7Sx4-WD	750	1/2-13	1/2	3/4	3/4	4-3/4	4	3/16
IL60-8Gx4-WD	IL60-8Sx4-WD	1000	5/8-11	5/8	3/4	3/4	4-3/4	4	3/16
IL60-9Gx4-WD	IL60-9Sx4-WD	1250	3/4-10	3/4	3/4	3/4	4-3/4	4	3/16
IL60-10Gx4-WD	IL60-10Sx4-WD	1500	1-8	1	1	3/4	5	4	1/2
IL60-6Gx5-WD	IL60-6Sx5-WD	500	3/8-16	1/2	3/4	3/4	5-3/4	5	3/16
IL60-7Gx5-WD	IL60-7Sx5-WD	750	1/2-13	1/2	3/4	3/4	5-3/4	5	3/16
IL60-8Gx5-WD	IL60-8Sx5-WD	1000	5/8-11	5/8	3/4	3/4	5-3/4	5	3/16
IL60-9Gx5-WD	IL60-9Sx5-WD	1250	3/4-10	3/4	3/4	3/4	5-3/4	5	3/16
IL60-10Gx5-WD	IL60-10Sx5-WD	1500	1-8	1	1	3/4	6	5	1/2
IL60-6Gx6-WD	IL60-6Sx6-WD	500	3/8-16	1/2	3/4	3/4	6-3/4	6	3/16
IL60-7Gx6-WD	IL60-7Sx6-WD	750	1/2-13	1/2	3/4	3/4	6-3/4	6	3/16
IL60-8Gx6-WD	IL60-8Sx6-WD	1000	5/8-11	5/8	3/4	3/4	6-3/4	6	3/16
IL60-9Gx6-WD	IL60-9Sx6-WD	1250	3/4-10	3/4	3/4	3/4	6-3/4	6	3/16
IL60-10Gx6-WD	IL60-10Sx6-WD	1500	1-8	1	1	3/4	7	6	1/2
IL60-7Gx8-WD	IL60-7Sx8-WD	750	1/2-13	1/2	3/4	3/4	8-3/4	8	3/16
IL60-8Gx8-WD	IL60-8Sx8-WD	1000	5/8-11	5/8	3/4	3/4	8-3/4	8	3/16
IL60-9Gx8-WD	IL60-9Sx8-WD	1250	3/4-10	3/4	3/4	3/4	8-3/4	8	3/16
IL60-10Gx8-WD	IL60-10Sx8-WD	1500	1-8	1	1	3/4	9	8	1/2

To order optional top broached hex, "allen drive," add "-BR".



TOGGLE PADS - STUD (SWIVEL SET SCREWS)

The IEC *Delrin® Base Stud Toggle Pad* features an exclusive ball design that minimizes base separation. Ideal for heavy-duty load requirements. The threaded female socket allows use of your own stud or bolt. Integrated ball and swivel socket provide a low-friction support interface. Standard steel finish is corrosion resistant zinc-plated gold irridite. Other finishes available upon request.

Features

- Steel/stainless steel options
- Integrated ball and stud
- Adjustable height
- Base adjusts 15° off centerline
- Standard gold irridite zinc finish
- Black oxide or clear chromate options
- Black delrin available as custom
- Non-tilt and extended stud length designs (2" - 8")
- Optional Top-A-Just™ shown at right. (add "-BR" to P/N)

Applications

- Electronic equipment
- Enclosures
- Conveyors
- Machinery
- Fixtures
- Tooling

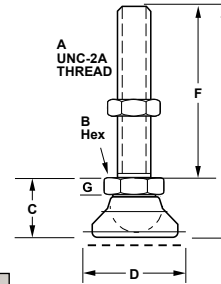

TOGGLE PADS (DELRIN BASE) - STEEL & STAINLESS STEEL STUD

Steel	Stainless	Load	A	B	C	D	E	F	G
IL62-4G-WD	IL62-4S-WD	100	1/4-20	1/2	3/4	1-1/4	2-3/4	2	3/16
IL62-5G-WD	IL62-5S-WD	300	5/16-18	1/2	3/4	1-1/4	2-3/4	2	3/16
IL62-6G-WD	IL62-6S-WD	500	3/8-16	1/2	3/4	1-1/4	2-3/4	2	3/16
IL62-7G-WD	IL62-7S-WD	750	1/2-13	1/2	3/4	1-1/4	2-3/4	2	3/16
IL62-8G-WD	IL62-8S-WD	1000	5/8-11	5/8	3/4	1-1/4	2-3/4	2	3/16
IL62-9G-WD	IL62-9S-WD	1250	3/4-10	3/4	3/4	1-1/4	2-3/4	2	3/16
IL62-10G-WD	IL62-10S-WD	1500	1-8	1	1	1-1/4	3	2	1/2
IL62-4Gx3-WD	IL62-4Sx3-WD	100	1/4-20	1/2	3/4	1-1/4	3-3/4	3	3/16
IL62-5Gx3-WD	IL62-5Sx3-WD	300	5/16-18	1/2	3/4	1-1/4	3-3/4	3	3/16
IL62-6Gx3-WD	IL62-6Sx3-WD	500	3/8-16	1/2	3/4	1-1/4	3-3/4	3	3/16
IL62-7Gx3-WD	IL62-7Sx3-WD	750	1/2-13	1/2	3/4	1-1/4	3-3/4	3	3/16
IL62-8Gx3-WD	IL62-8Sx3-WD	1000	5/8-11	5/8	3/4	1-1/4	3-3/4	3	3/16
IL62-9Gx3-WD	IL62-9Sx3-WD	1250	3/4-10	3/4	3/4	1-1/4	3-3/4	3	3/16
IL62-10Gx3-WD	IL62-10Sx3-WD	1500	1-8	1	1	1-1/4	4	3	1/2
IL62-5Gx4-WD	IL62-5Sx4-WD	300	5/16-18	1/2	3/4	1-1/4	4-3/4	4	3/16
IL62-6Gx4-WD	IL62-6Sx4-WD	500	3/8-16	1/2	3/4	1-1/4	4-3/4	4	3/16
IL62-7Gx4-WD	IL62-7Sx4-WD	750	1/2-13	1/2	3/4	1-1/4	4-3/4	4	3/16
IL62-8Gx4-WD	IL62-8Sx4-WD	1000	5/8-11	5/8	3/4	1-1/4	4-3/4	4	3/16
IL62-9Gx4-WD	IL62-9Sx4-WD	1250	3/4-10	3/4	3/4	1-1/4	4-3/4	4	3/16
IL62-10Gx4-WD	IL62-10Sx4-WD	1500	1-8	1	1	1-1/4	5	4	1/2
IL62-6Gx5-WD	IL62-6Sx5-WD	500	3/8-16	1/2	3/4	1-1/4	5-3/4	5	3/16
IL62-7Gx5-WD	IL62-7Sx5-WD	750	1/2-13	1/2	3/4	1-1/4	5-3/4	5	3/16
IL62-8Gx5-WD	IL62-8Sx5-WD	1000	5/8-11	5/8	3/4	1-1/4	5-3/4	5	3/16
IL62-9Gx5-WD	IL62-9Sx5-WD	1250	3/4-10	3/4	3/4	1-1/4	5-3/4	5	3/16
IL62-10Gx5-WD	IL62-10Sx5-WD	1500	1-8	1	1	1-1/4	6	5	1/2
IL62-6Gx6-WD	IL62-6Sx6-WD	500	3/8-16	1/2	3/4	1-1/4	6-3/4	6	3/16
IL62-7Gx6-WD	IL62-7Sx6-WD	750	1/2-13	1/2	3/4	1-1/4	6-3/4	6	3/16
IL62-8Gx6-WD	IL62-8Sx6-WD	1000	5/8-11	5/8	3/4	1-1/4	6-3/4	6	3/16
IL62-9Gx6-WD	IL62-9Sx6-WD	1250	3/4-10	3/4	3/4	1-1/4	6-3/4	6	3/16
IL62-10Gx6-WD	IL62-10Sx6-WD	1500	1-8	1	1	1-1/4	7	6	1/2
IL62-7Gx8-WD	IL62-7Sx8-WD	750	1/2-13	1/2	3/4	1-1/4	8-3/4	8	3/16
IL62-8Gx8-WD	IL62-8Sx8-WD	1000	5/8-11	5/8	3/4	1-1/4	8-3/4	8	3/16
IL62-9Gx8-WD	IL62-9Sx8-WD	1250	3/4-10	3/4	3/4	1-1/4	8-3/4	8	3/16
IL62-10Gx8-WD	IL62-10Sx8-WD	1500	1-8	1	1	1-1/4	9	8	1/2

To order optional top broached hex, "allen drive," add "-BR".



METRIC TOGGLE PADS / SWIVEL SET SCREWS

The IEC *Metric Toggle Pads (Swivel Set Screws)* feature an exclusive ball design that minimizes base separation. Ideal for heavy-duty load requirements. Integrated ball and swivel socket provide a low-friction support interface. Perfect for cabinets, instruments, machinery and equipment.

Features

- Steel/stainless steel options
- Integrated ball and stud
- Adjustable height
- Base adjusts 15° off centerline
- Standard gold irridite zinc finish
- Black oxide or clear chromate options
- Optional rubber pad (add -P)
- Non-tilt and extended stud length designs (2" - 8")
- Optional Top-A-Just™ shown at right. (add "-BR" to P/N)

Applications

- Electronic equipment
- Enclosures
- Work tables
- Display racks
- Fixtures
- Tooling

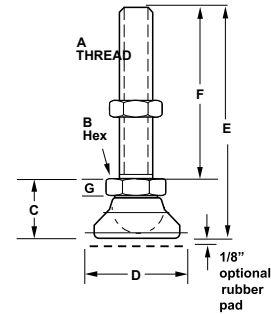

LOW PROFILE - METRIC STEEL & STAINLESS STEEL

Steel	Stainless	Load	A	B	C	D	E	F	G
IL60-M6G	IL60-M6S	100	M6x1	1/2	3/4	3/4	2-3/4	2	3/16
IL60-M8G	IL60-M8S	500	M8x1.25	1/2	3/4	3/4	2-3/4	2	3/16
IL60-M10G	IL60-M10S	1000	M10x1.50	1/2	3/4	3/4	2-3/4	2	3/16
IL60-M12G	IL60-M12S	2000	M12x1.75	1/2	3/4	3/4	2-3/4	2	3/16
IL60-M16G	IL60-M16S	3000	M16x2.00	5/8	3/4	3/4	2-3/4	2	3/16
IL60-M20G	IL60-M20S	4000	M20x2.50	3/4	3/4	3/4	2-3/4	2	3/16
IL60-M24G	IL60-M24S	5000	M24x3.00	1	1	3/4	3	2	1/2
IL60-M8Gx3	IL60-M8Sx3	500	M8x1.25	1/2	3/4	3/4	3-3/4	3	3/16
IL60-M10Gx3	IL60-M10Sx3	1000	M10x1.50	1/2	3/4	3/4	3-3/4	3	3/16
IL60-M12Gx3	IL60-M12Sx3	2000	M12x1.75	1/2	3/4	3/4	3-3/4	3	3/16
IL60-M16Gx3	IL60-M16Sx3	3000	M16x2.00	5/8	3/4	3/4	3-3/4	3	3/16
IL60-M20Gx3	IL60-M20Sx3	4000	M20x2.50	3/4	3/4	3/4	3-3/4	3	3/16
IL60-M24Gx3	IL60-M24Sx3	5000	M24x3.00	1	1	3/4	4	3	1/2
IL60-M8Gx4	IL60-M8Sx4	500	M8x1.25	1/2	3/4	3/4	4-3/4	4	3/16
IL60-M10Gx4	IL60-M10Sx4	1000	M10x1.50	1/2	3/4	3/4	4-3/4	4	3/16
IL60-M12Gx4	IL60-M12Sx4	2000	M12x1.75	1/2	3/4	3/4	4-3/4	4	3/16
IL60-M16Gx4	IL60-M16Sx4	3000	M16x2.00	5/8	3/4	3/4	4-3/4	4	3/16
IL60-M20Gx4	IL60-M20Sx4	4000	M20x2.50	3/4	3/4	3/4	4-3/4	4	3/16
IL60-M24Gx4	IL60-M24Sx4	5000	M24x3.00	1	1	3/4	5	4	1/2
IL60-M10Gx5	IL60-M10Sx5	1000	M10x1.50	1/2	3/4	3/4	5-3/4	5	3/16
IL60-M12Gx5	IL60-M12Sx5	2000	M12x1.75	1/2	3/4	3/4	5-3/4	5	3/16
IL60-M16Gx5	IL60-M16Sx5	3000	M16x2.00	5/8	3/4	3/4	5-3/4	5	3/16
IL60-M20Gx5	IL60-M20Sx5	4000	M20x2.50	3/4	3/4	3/4	5-3/4	5	3/16
IL60-M24Gx5	IL60-M24Sx5	5000	M24x3.00	1	1	3/4	6	5	1/2
IL60-M10Gx6	IL60-M10Sx6	1000	M10x1.50	1/2	3/4	3/4	6-3/4	6	3/16
IL60-M12Gx6	IL60-M12Sx6	2000	M12x1.75	1/2	3/4	3/4	6-3/4	6	3/16
IL60-M16Gx6	IL60-M16Sx6	3000	M16x2.00	5/8	3/4	3/4	6-3/4	6	3/16
IL60-M20Gx6	IL60-M20Sx6	4000	M20x2.50	3/4	3/4	3/4	6-3/4	6	3/16
IL60-M24Gx6	IL60-M24Sx6	5000	M24x3.00	1	1	3/4	7	6	1/2
IL60-M12Gx8	IL60-M12Sx8	2000	M12x1.75	1/2	3/4	3/4	8-3/4	8	3/16
IL60-M16Gx8	IL60-M16Sx8	3000	M16x2.00	5/8	3/4	3/4	8-3/4	8	3/16
IL60-M20Gx8	IL60-M20Sx8	4000	M20x2.50	3/4	3/4	3/4	8-3/4	8	3/16
IL60-M24Gx8	IL60-M24Sx8	5000	M24x3.00	1	1	3/4	9	8	1/2

To order with 1/8" black rubber pad, (add "-P"). To order optional top broached hex, "allen drive," add "-BR".

Top Hex (Allen-drive) Thread & Hex Size							
Thread	M6x1	M8x1.25	M10x1.50	M12x1.75	M16x2.00	M20x2.50	M24x3.00
Hex Size	3mm	4mm	5mm	6mm	8mm	10mm	12mm



METRIC TOGGLE PADS / SWIVEL SET SCREWS

The IEC *Metric Toggle Pads (Swivel Set Screws)* feature an exclusive ball design that minimizes base separation. Ideal for heavy-duty load requirements. Integrated ball and swivel socket provide a low-friction support interface. Perfect for cabinets, instruments, machinery and equipment.

Features

- Steel/stainless steel options
- Integrated ball and stud
- Adjustable height
- Base adjusts 15° off centerline
- Standard gold irridite zinc finish
- Black oxide or clear chromate options
- Optional rubber pad (add -P)
- Non-tilt and extended stud length designs (2" - 8")
- Optional Top-A-Just™ shown at right. (add "-BR" to P/N)

Applications

- Electronic equipment
- Enclosures
- Work tables
- Display racks
- Fixtures
- Tooling

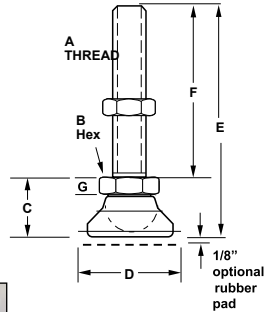

LOW PROFILE - METRIC STEEL & STAINLESS STEEL

Steel	Stainless	Load	A	B	C	D	E	F	G
IL62-M6G	IL62-M6S	100	M6x1	1/2	3/4	1-1/4	2-3/4	2	3/16
IL62-M8G	IL62-M8S	500	M8x1.25	1/2	3/4	1-1/4	2-3/4	2	3/16
IL62-M10G	IL62-M10S	1000	M10x1.50	1/2	3/4	1-1/4	2-3/4	2	3/16
IL62-M12G	IL62-M12S	2000	M12x1.75	1/2	3/4	1-1/4	2-3/4	2	3/16
IL62-M16G	IL62-M16S	3000	M16x2.00	5/8	3/4	1-1/4	2-3/4	2	3/16
IL62-M20G	IL62-M20S	4000	M20x2.50	3/4	3/4	1-1/4	2-3/4	2	3/16
IL62-M24G	IL62-M24S	5000	M24x3.00	1	1	1-1/4	3	2	1/2
IL62-M8Gx3	IL62-M8Sx3	500	M8x1.25	1/2	3/4	1-1/4	3-3/4	3	3/16
IL62-M10Gx3	IL62-M10Sx3	1000	M10x1.50	1/2	3/4	1-1/4	3-3/4	3	3/16
IL62-M12Gx3	IL62-M12Sx3	2000	M12x1.75	1/2	3/4	1-1/4	3-3/4	3	3/16
IL62-M16Gx3	IL62-M16Sx3	3000	M16x2.00	5/8	3/4	1-1/4	3-3/4	3	3/16
IL62-M20Gx3	IL62-M20Sx3	4000	M20x2.50	3/4	3/4	1-1/4	3-3/4	3	3/16
IL62-M24Gx3	IL62-M24Sx3	5000	M24x3.00	1	1	1-1/4	4	3	1/2
IL62-M8Gx4	IL62-M8Sx4	500	M8x1.25	1/2	3/4	1-1/4	4-3/4	4	3/16
IL62-M10Gx4	IL62-M10Sx4	1000	M10x1.50	1/2	3/4	1-1/4	4-3/4	4	3/16
IL62-M12Gx4	IL62-M12Sx4	2000	M12x1.75	1/2	3/4	1-1/4	4-3/4	4	3/16
IL62-M16Gx4	IL62-M16Sx4	3000	M16x2.00	5/8	3/4	1-1/4	4-3/4	4	3/16
IL62-M20Gx4	IL62-M20Sx4	4000	M20x2.50	3/4	3/4	1-1/4	4-3/4	4	3/16
IL62-M24Gx4	IL62-M24Sx4	5000	M24x3.00	1	1	1-1/4	5	4	1/2
IL62-M10Gx5	IL62-M10Sx5	1000	M10x1.50	1/2	3/4	1-1/4	5-3/4	5	3/16
IL62-M12Gx5	IL62-M12Sx5	2000	M12x1.75	1/2	3/4	1-1/4	5-3/4	5	3/16
IL62-M16Gx5	IL62-M16Sx5	3000	M16x2.00	5/8	3/4	1-1/4	5-3/4	5	3/16
IL62-M20Gx5	IL62-M20Sx5	4000	M20x2.50	3/4	3/4	1-1/4	5-3/4	5	3/16
IL62-M24Gx5	IL62-M24Sx5	5000	M24x3.00	1	1	1-1/4	6	5	1/2
IL62-M10Gx6	IL62-M10Sx6	1000	M10x1.50	1/2	3/4	1-1/4	6-3/4	6	3/16
IL62-M12Gx6	IL62-M12Sx6	2000	M12x1.75	1/2	3/4	1-1/4	6-3/4	6	3/16
IL62-M16Gx6	IL62-M16Sx6	3000	M16x2.00	5/8	3/4	1-1/4	6-3/4	6	3/16
IL62-M20Gx6	IL62-M20Sx6	4000	M20x2.50	3/4	3/4	1-1/4	6-3/4	6	3/16
IL62-M24Gx6	IL62-M24Sx6	5000	M24x3.00	1	1	1-1/4	7	6	1/2
IL62-M12Gx8	IL62-M12Sx8	2000	M12x1.75	1/2	3/4	1-1/4	8-3/4	8	3/16
IL62-M16Gx8	IL62-M16Sx8	3000	M16x2.00	5/8	3/4	1-1/4	8-3/4	8	3/16
IL62-M20Gx8	IL62-M20Sx8	4000	M20x2.50	3/4	3/4	1-1/4	8-3/4	8	3/16
IL62-M24Gx8	IL62-M24Sx8	5000	M24x3.00	1	1	1-1/4	9	8	1/2

To order with 1/8" black rubber pad, (add "-P"). To order optional top broached hex, "allen drive," add "-BR".

Top Hex (Allen-drive) Thread & Hex Size							
Thread	M6x1	M8x1.25	M10x1.50	M12x1.75	M16x2.00	M20x2.50	M24x3.00
Hex Size	3mm	4mm	5mm	6mm	8mm	10mm	12mm



INTERNATIONAL EQUIPMENT COMPONENTS, INC.
 Phone: 562.597.4533 eMail: sales@iec-corp.com
 Web: www.levelingmounts.com & www.iec-corp.com

HEAVY-DUTY LEVELERS

TOGGLE PADS - STUD METRIC DELRIN BASE

TOGGLE PADS - METRIC STUD (SWIVEL SET SCREWS)

The IEC *Metric Delrin® Base Stud Toggle Pad* features an exclusive ball design that minimizes base separation. Ideal for heavy-duty load requirements. The threaded female socket allows use of your own stud or bolt. Integrated ball and swivel socket provide a low-friction support interface. Standard steel finish is corrosion resistant zinc-plated gold irridite. Other finishes available upon request.

Features

- Steel/stainless steel options
- Integrated ball and stud
- Adjustable height
- Base adjusts 15° off centerline
- Standard gold irridite zinc finish
- Black oxide or clear chromate options
- Black delrin available as custom
- Non-tilt and extended stud length designs (2" - 8")
- Optional Top-A-Just™ shown at right. (add "-BR" to P/N)

Applications

- Electronic equipment
- Enclosures
- Conveyors
- Machinery
- Fixtures
- Tooling

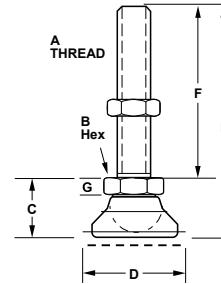

LOW PROFILE - METRIC (DELRIN BASE) STEEL & STAINLESS STEEL

Steel	Stainless	Load	A	B	C	D	E	F	G
IL60-M6G-WD	IL60-M6S-WD	100	M6x1	1/2	3/4	3/4	2-3/4	2	3/16
IL60-M8G-WD	IL60-M8S-WD	300	M8x1.25	1/2	3/4	3/4	2-3/4	2	3/16
IL60-M10G-WD	IL60-M10S-WD	500	M10x1.50	1/2	3/4	3/4	2-3/4	2	3/16
IL60-M12G-WD	IL60-M12S-WD	750	M12x1.75	1/2	3/4	3/4	2-3/4	2	3/16
IL60-M16G-WD	IL60-M16S-WD	1000	M16x2.00	5/8	3/4	3/4	2-3/4	2	3/16
IL60-M20G-WD	IL60-M20S-WD	1250	M20x2.50	3/4	3/4	3/4	2-3/4	2	3/16
IL60-M24G-WD	IL60-M24S-WD	1500	M24x3.00	1	1	3/4	3	2	1/2
IL60-M8Gx3-WD	IL60-M8Sx3-WD	300	M8x1.25	1/2	3/4	3/4	3-3/4	3	3/16
IL60-M10Gx3-WD	IL60-M10Sx3-WD	500	M10x1.50	1/2	3/4	3/4	3-3/4	3	3/16
IL60-M12Gx3-WD	IL60-M12Sx3-WD	750	M12x1.75	1/2	3/4	3/4	3-3/4	3	3/16
IL60-M16Gx3-WD	IL60-M16Sx3-WD	1000	M16x2.00	5/8	3/4	3/4	3-3/4	3	3/16
IL60-M20Gx3-WD	IL60-M20Sx3-WD	1250	M20x2.50	3/4	3/4	3/4	3-3/4	3	3/16
IL60-M24Gx3-WD	IL60-M24Sx3-WD	1500	M24x3.00	1	1	3/4	4	3	1/2
IL60-M8Gx4-WD	IL60-M8Sx4-WD	300	M8x1.25	1/2	3/4	3/4	4-3/4	4	3/16
IL60-M10Gx4-WD	IL60-M10Sx4-WD	500	M10x1.50	1/2	3/4	3/4	4-3/4	4	3/16
IL60-M12Gx4-WD	IL60-M12Sx4-WD	750	M12x1.75	1/2	3/4	3/4	4-3/4	4	3/16
IL60-M16Gx4-WD	IL60-M16Sx4-WD	1000	M16x2.00	5/8	3/4	3/4	4-3/4	4	3/16
IL60-M20Gx4-WD	IL60-M20Sx4-WD	1250	M20x2.50	3/4	3/4	3/4	4-3/4	4	3/16
IL60-M24Gx4-WD	IL60-M24Sx4-WD	1500	M24x3.00	1	1	3/4	5	4	1/2
IL60-M10Gx5-WD	IL60-M10Sx5-WD	500	M10x1.50	1/2	3/4	3/4	5-3/4	5	3/16
IL60-M12Gx5-WD	IL60-M12Sx5-WD	750	M12x1.75	1/2	3/4	3/4	5-3/4	5	3/16
IL60-M16Gx5-WD	IL60-M16Sx5-WD	1000	M16x2.00	5/8	3/4	3/4	5-3/4	5	3/16
IL60-M20Gx5-WD	IL60-M20Sx5-WD	1250	M20x2.50	3/4	3/4	3/4	5-3/4	5	3/16
IL60-M24Gx5-WD	IL60-M24Sx5-WD	1500	M24x3.00	1	1	3/4	6	5	1/2
IL60-M10Gx6-WD	IL60-M10Sx6-WD	500	M10x1.50	1/2	3/4	3/4	6-3/4	6	3/16
IL60-M12Gx6-WD	IL60-M12Sx6-WD	750	M12x1.75	1/2	3/4	3/4	6-3/4	6	3/16
IL60-M16Gx6-WD	IL60-M16Sx6-WD	1000	M16x2.00	5/8	3/4	3/4	6-3/4	6	3/16
IL60-M20Gx6-WD	IL60-M20Sx6-WD	1250	M20x2.50	3/4	3/4	3/4	6-3/4	6	3/16
IL60-M24Gx6-WD	IL60-M24Sx6-WD	1500	M24x3.00	1	1	3/4	7	6	1/2
IL60-M12Gx8-WD	IL60-M12Sx8-WD	750	M12x1.75	1/2	3/4	3/4	8-3/4	8	3/16
IL60-M16Gx8-WD	IL60-M16Sx8-WD	1000	M16x2.00	5/8	3/4	3/4	8-3/4	8	3/16
IL60-M20Gx8-WD	IL60-M20Sx8-WD	1250	M20x2.50	3/4	3/4	3/4	8-3/4	8	3/16
IL60-M24Gx8-WD	IL60-M24Sx8-WD	1500	M24x3.00	1	1	3/4	9	8	1/2

To order optional top broached hex, "allen drive," add "-BR".

Top Hex (Allen-drive) Thread & Hex Size							
Thread	M6x1	M8x1.25	M10x1.50	M12x1.75	M16x2.00	M20x2.50	M24x3.00
Hex Size	3mm	4mm	5mm	6mm	8mm	10mm	12mm



TOGGLE PADS - METRIC STUD (SWIVEL SET SCREWS)

The IEC *Metric Delrin® Base Stud Toggle Pad* features an exclusive ball design that minimizes base separation. Ideal for heavy-duty load requirements. The threaded female socket allows use of your own stud or bolt. Integrated ball and swivel socket provide a low-friction support interface. Standard steel finish is corrosion resistant zinc-plated gold irridite. Other finishes available upon request.

Features

- Steel/stainless steel options
- Integrated ball and stud
- Adjustable height
- Base adjusts 15° off centerline
- Standard gold irridite zinc finish
- Black oxide or clear chromate options
- Black delrin available as custom
- Non-tilt and extended stud length designs (2" - 8")
- Optional Top-A-Just™ shown at right. (add "-BR" to P/N)

Applications

- Electronic equipment
- Enclosures
- Conveyors
- Machinery
- Fixtures
- Tooling

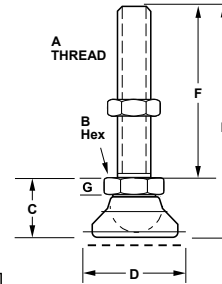

LOW PROFILE - METRIC STEEL & STAINLESS STEEL

Steel	Stainless	Load	A	B	C	D	E	F	G
IL62-M6G-WD	IL62-M6S-WD	100	M6x1	1/2	3/4	1-1/4	2-3/4	2	3/16
IL62-M8G-WD	IL62-M8S-WD	300	M8x1.25	1/2	3/4	1-1/4	2-3/4	2	3/16
IL62-M10G-WD	IL62-M10S-WD	500	M10x1.50	1/2	3/4	1-1/4	2-3/4	2	3/16
IL62-M12G-WD	IL62-M12S-WD	750	M12x1.75	1/2	3/4	1-1/4	2-3/4	2	3/16
IL62-M16G-WD	IL62-M16S-WD	1000	M16x2.00	5/8	3/4	1-1/4	2-3/4	2	3/16
IL62-M20G-WD	IL62-M20S-WD	1250	M20x2.50	3/4	3/4	1-1/4	2-3/4	2	3/16
IL62-M24G-WD	IL62-M24S-WD	1500	M24x3.00	1	1	1-1/4	3	2	1/2
IL62-M8Gx3-WD	IL62-M8Sx3-WD	300	M8x1.25	1/2	3/4	1-1/4	3-3/4	3	3/16
IL62-M10Gx3-WD	IL62-M10Sx3-WD	500	M10x1.50	1/2	3/4	1-1/4	3-3/4	3	3/16
IL62-M12Gx3-WD	IL62-M12Sx3-WD	750	M12x1.75	1/2	3/4	1-1/4	3-3/4	3	3/16
IL62-M16Gx3-WD	IL62-M16Sx3-WD	1000	M16x2.00	5/8	3/4	1-1/4	3-3/4	3	3/16
IL62-M20Gx3-WD	IL62-M20Sx3-WD	1250	M20x2.50	3/4	3/4	1-1/4	3-3/4	3	3/16
IL62-M24Gx3-WD	IL62-M24Sx3-WD	1500	M24x3.00	1	1	1-1/4	4	3	1/2
IL62-M8Gx4-WD	IL62-M8Sx4-WD	300	M8x1.25	1/2	3/4	1-1/4	4-3/4	4	3/16
IL62-M10Gx4-WD	IL62-M10Sx4-WD	500	M10x1.50	1/2	3/4	1-1/4	4-3/4	4	3/16
IL62-M12Gx4-WD	IL62-M12Sx4-WD	750	M12x1.75	1/2	3/4	1-1/4	4-3/4	4	3/16
IL62-M16Gx4-WD	IL62-M16Sx4-WD	1000	M16x2.00	5/8	3/4	1-1/4	4-3/4	4	3/16
IL62-M20Gx4-WD	IL62-M20Sx4-WD	1250	M20x2.50	3/4	3/4	1-1/4	4-3/4	4	3/16
IL62-M24Gx4-WD	IL62-M24Sx4-WD	1500	M24x3.00	1	1	1-1/4	5	4	1/2
IL62-M10Gx5-WD	IL62-M10Sx5-WD	500	M10x1.50	1/2	3/4	1-1/4	5-3/4	5	3/16
IL62-M12Gx5-WD	IL62-M12Sx5-WD	750	M12x1.75	1/2	3/4	1-1/4	5-3/4	5	3/16
IL62-M16Gx5-WD	IL62-M16Sx5-WD	1000	M16x2.00	5/8	3/4	1-1/4	5-3/4	5	3/16
IL62-M20Gx5-WD	IL62-M20Sx5-WD	1250	M20x2.50	3/4	3/4	1-1/4	5-3/4	5	3/16
IL62-M24Gx5-WD	IL62-M24Sx5-WD	1500	M24x3.00	1	1	1-1/4	6	5	1/2
IL62-M10Gx6-WD	IL62-M10Sx6-WD	500	M10x1.50	1/2	3/4	1-1/4	6-3/4	6	3/16
IL62-M12Gx6-WD	IL62-M12Sx6-WD	750	M12x1.75	1/2	3/4	1-1/4	6-3/4	6	3/16
IL62-M16Gx6-WD	IL62-M16Sx6-WD	1000	M16x2.00	5/8	3/4	1-1/4	6-3/4	6	3/16
IL62-M20Gx6-WD	IL62-M20Sx6-WD	1250	M20x2.50	3/4	3/4	1-1/4	6-3/4	6	3/16
IL62-M24Gx6-WD	IL62-M24Sx6-WD	1500	M24x3.00	1	1	1-1/4	7	6	1/2
IL62-M12Gx8-WD	IL62-M12Sx8-WD	750	M12x1.75	1/2	3/4	1-1/4	8-3/4	8	3/16
IL62-M16Gx8-WD	IL62-M16Sx8-WD	1000	M16x2.00	5/8	3/4	1-1/4	8-3/4	8	3/16
IL62-M20Gx8-WD	IL62-M20Sx8-WD	1250	M20x2.50	3/4	3/4	1-1/4	8-3/4	8	3/16
IL62-M24Gx8-WD	IL62-M24Sx8-WD	1500	M24x3.00	1	1	1-1/4	9	8	1/2

To order optional top broached hex, "allen drive," add "-BR".

Top Hex (Allen-drive) Thread & Hex Size							
Thread	M6x1	M8x1.25	M10x1.50	M12x1.75	M16x2.00	M20x2.50	M24x3.00
Hex Size	3mm	4mm	5mm	6mm	8mm	10mm	12mm



INTERNATIONAL EQUIPMENT COMPONENTS, INC.

Phone: 562.597.4533 eMail: sales@iec-corp.com

Web: www.levelingmounts.com & www.iec-corp.com

HEAVY-DUTY LEVELERS

THREADED TUBE ENDS

THREADED TUBE ENDS

These round, square and rectangular threaded tube ends are made of fiberglass reinforced black nylon material with a brass threaded insert. Many more threaded tube ends, weld nuts, t-nuts for wood applications, corner and side brackets can be found in our *Light Duty Leveler* catalog.

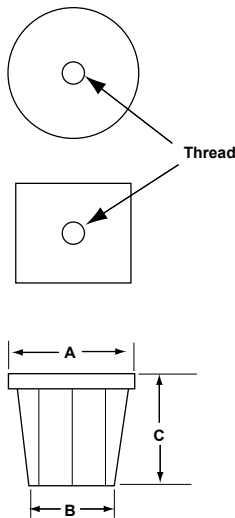

P/N (round)	Thread	Load	A	B	C	Tubing Gauge	Wall Thickness
IL27-R7N	1/2-13	1000	1-1/2	1.37	1-3/4	16GA	0.65-0.75
IL27-R8N	5/8-11	1000	1-1/2	1.37	1-3/4	16GA	0.65-0.75
IL27-R9N	3/4-10	1000	1-1/2	1.37	1-3/4	16GA	0.65-0.75
IL27-RM16N	M16	1000	1-1/2	1.37	1-3/4	16GA	0.65-0.75
IL27-R7N5	1/2-13	1000	2	1.78	2	SCH.5	0.65
IL27-R8N5	5/8-11	1000	2	1.78	2	SCH.5	0.65
IL27-R9N5	3/4-10	1000	2	1.78	2	SCH.5	0.65
IL27-RM16N5	M16	1000	2	1.78	2	SCH.5	0.65
IL27-R7N10	1/2-13	1000	2	1.69	2	SCH.10	.109
IL27-R8N10	5/8-11	1000	2	1.69	2	SCH.10	.109
IL27-R9N10	3/4-10	1760	2	1.69	2	SCH.10	.109
IL27-RM16N10	M16	1760	2	1.69	2	SCH.10	.109
IL27A-R7N	1/2-13	1000	2	1.91	2	16GA	0.65-0.75
IL27A-R8N	5/8-11	1000	2	1.91	2	16GA	0.65-0.75
IL27A-R9N	3/4-10	1760	2	1.91	2	16GA	0.65-0.75
IL27A-RM16N	M16	1760	2	1.91	2	16GA	0.65-0.75

P/N (square)	Thread	Load	A	B	C	Tubing Gauge	Wall Thickness
IL27-7N	1/2-13	1000	1-1/2	1.37	1-3/4	16GA	0.65-0.75
IL27-8N	5/8-11	1000	1-1/2	1.37	1-3/4	16GA	0.65-0.75
IL27-9N	3/4-10	1000	1-1/2	1.37	1-3/4	16GA	0.65-0.75
IL27-M16N	M16	1000	1-1/2	1.37	1-3/4	16GA	0.65-0.75
IL27-7N2	1/2-13	1000	1-1/2	1.26	1-3/4	11GA	.109-.120
IL27-8N2	5/8-11	1000	1-1/2	1.26	1-3/4	11GA	.109-.120
IL27-9N2	3/4-10	1000	1-1/2	1.26	1-3/4	11GA	.109-.120
IL27-M16N2	M16	1000	1-1/2	1.26	1-3/4	11GA	.109-.120
IL27A-7N	1/2-13	1000	2	1.87	2	16GA	0.65-0.75
IL27A-8N	5/8-11	1000	2	1.87	2	16GA	0.65-0.75
IL27A-9N	3/4-10	1760	2	1.87	2	16GA	0.65-0.75
IL27A-M16N	M16	1760	2	1.87	2	16GA	0.65-0.75
IL27A-7N2	1/2-13	1000	2	1.78	2	11GA	.109-.120
IL27A-8N2	5/8-11	1000	2	1.78	2	11GA	.109-.120
IL27A-9N2	3/4-10	1760	2	1.78	2	11GA	.109-.120
IL27A-M16N2	M16	1760	2	1.78	2	11GA	.109-.120

P/N (rect.)	Thread	Load	A	B	C	Tubing Gauge	Wall Thickness
IL27A-RE-7N2	1/2-13	1760	2X3	1.78	1-1/2	11GA	.125
IL27A-RE-8N2	5/8-11	1760	2X3	1.78	1-1/2	11GA	.125
IL27A-RE-9N2	3/4-10	1760	2X3	1.78	1-1/2	11GA	.125
IL27A-RE-M16N2	M16x2.0	1760	2X3	1.78	1-1/2	11GA	.125



Your Contact Information

NAME:	TITLE:
<input type="text"/>	<input type="text"/>
COMPANY:	E-MAIL:
<input type="text"/>	<input type="text"/>
STREET ADDRESS OR POB:	CITY:
<input type="text"/>	<input type="text"/>
STATE:	ZIP CODE:
<input type="text"/>	<input type="text"/>
PHONE:	FAX:
<input type="text"/>	<input type="text"/>

Standard Product Request

ITEM #	IEC PART NUMBER	DESCRIPTION / COMMENTS	QUANTITY
1	<input type="text"/>	<input type="text"/>	<input type="text"/>
2	<input type="text"/>	<input type="text"/>	<input type="text"/>
3	<input type="text"/>	<input type="text"/>	<input type="text"/>
4	<input type="text"/>	<input type="text"/>	<input type="text"/>
5	<input type="text"/>	<input type="text"/>	<input type="text"/>

Custom Product Request SIMILAR TO IEC PART NUMBER:

BASE	STUD
DIAMETER:	LENGTH:
MATERIAL:	THREAD:
SWIVEL:	MATERIAL:
FINISH:	SWIVEL:
	FINISH:

OPTIONAL FEATURES

TOP-A-JUST:	INTERNAL BROACH:
NON-SKID PAD:	HEX HEAD:
LAG HOLES:	SQUARE HEAD:
HEAT TREATED STUD:	TOP SLOT:
QUANTITY REQUESTED:	EST ANNUAL USAGE:
Comments / Special Instructions:	
<input type="text"/>	

PLEASE FAX THIS FORM TO: 562-498-2275



INTERNATIONAL EQUIPMENT COMPONENTS, INC.

Phone: **562.597.4533** eMail: **sales@iec-corp.com**

Web: **www.levelingmounts.com & www.iec-corp.com**

HEAVY-DUTY LEVELERS

WARRANTY

Warranty & Disclaimer

IEC warrants each product against defects in workmanship and material for 90 days from the date of delivery to the user. The warranty is limited to the repair or replacement of any part(s) which are found by IEC to be defective and does not apply to ordinary wear, tear, abuse, misapplications and altered products.

All data, dimensions and tables have been thoroughly checked but we can not assume liability for any possible errors or omissions. If you find an error, please notify us so we can correct it for future editions. We reserve the right to change designs and/or specifications without notice. In the event of a change, every attempt will be made to notify the current users.

IEC INTERNATIONAL EQUIPMENT COMPONENTS, INC.
www.levelingmounts.com & www.iec-corp.com

HEAVY-DUTY LEVELERS

ANY THREAD ... ANY LENGTH ... ANY BASE

**LEVEL
ALIGN
STABILIZE
PROTECT**

Ph. 562.597.4533

IEC INTERNATIONAL EQUIPMENT COMPONENTS, INC.
www.levelingmounts.com & www.iec-corp.com

MEDIUM-DUTY LEVELERS

ANY THREAD ... ANY LENGTH ... ANY BASE

**LEVEL
ALIGN
STABILIZE
PROTECT**

Ph. 562.597.4533

IEC INTERNATIONAL EQUIPMENT COMPONENTS, INC.
www.levelingmounts.com & www.iec-corp.com

LIGHT-DUTY LEVELERS

ANY THREAD ... ANY LENGTH ... ANY BASE

**LEVEL
ALIGN
STABILIZE
PROTECT**

Ph. 562.597.4533

IEC INTERNATIONAL EQUIPMENT COMPONENTS, INC.
www.levelingmounts.com & www.iec-corp.com

METRIC LEVELERS

ANY THREAD ... ANY LENGTH ... ANY BASE

**LEVEL
ALIGN
STABILIZE
PROTECT**

Ph. 562.597.4533

**INTERNATIONAL
EQUIPMENT COMPONENTS, INC.**

2201 E. Willow Street, D-104,

Signal Hill, CA 90755

Email: sales@iec-corp.com

Phone: 1-562-597-4533

Fax: 1-562-498-2275

Web: www.iec-corp.com

IEC INTERNATIONAL EQUIPMENT COMPONENTS, INC.
www.levelingmounts.com & www.iec-corp.com

KNOB & HANDLE

**CLAMP
ADJUST
STABILIZE
FASTEN**

Ph. 562.597.4533

IEC INTERNATIONAL EQUIPMENT COMPONENTS, INC.
www.levelingmounts.com & www.iec-corp.com

CAP & PLUG PRODUCTS

**FEET
SLIDE
PROTECT
FINISH**

Ph. 562.597.4533

IEC INTERNATIONAL EQUIPMENT COMPONENTS, INC.
www.levelingmounts.com & www.iec-corp.com

**SURFACE PROTECTION
SLIDERS, GRIPPERS & FELT**

**CUSHION
QUIET
SLIDE
PROTECT**

Ph. 562.597.4533

IEC INTERNATIONAL EQUIPMENT COMPONENTS, INC.
www.levelingmounts.com & www.iec-corp.com

LEG & CASTER PRODUCTS

**LEVEL
EXTEND
SUPPORT
ROLL**

Ph. 562.597.4533